

Three-phase motors

Operating Instructions Size 50 - 315

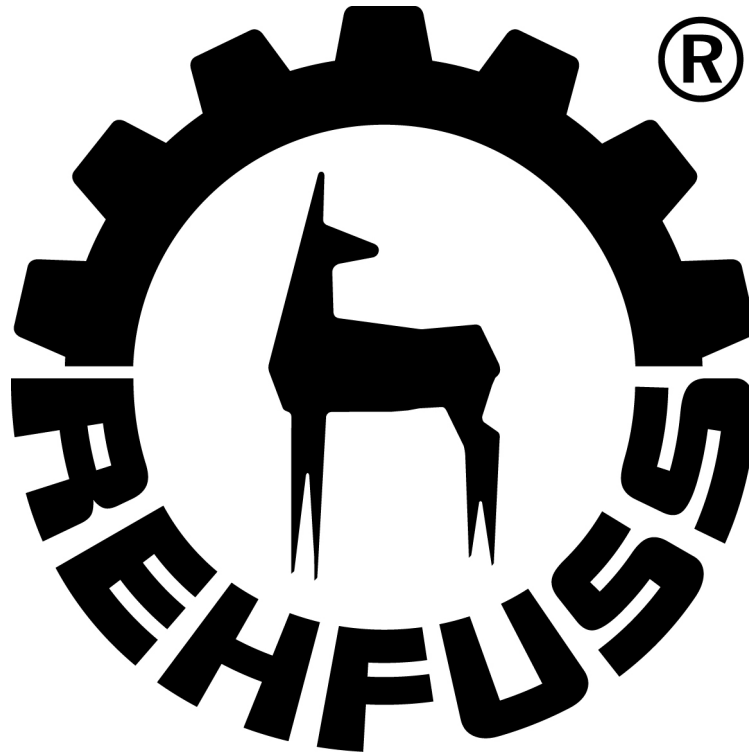

Rehfuß Drive Solutions GmbH
Vor dem Weißen Stein 21
72461 Albstadt, Germany

Fon +49 (0) 74 32 / 70 15 - 0
Fax +49 (0) 74 32 / 70 15 - 90

E-mail: info@rehfuss.com
Internet: www.rehfuss.com

Contents

issued 03/2022

1	Important Notes	3
2	Safety Notes	4
	2.1 Safety Notes Motors	4
	2.2 Transport/Storage	4
	2.3 Installation/Assembly	4
	2.4 Inspection/Maintenance	4
3	Assembly	5
	3.1 Basic Assembly Three-phase-motor	5
	3.2 Basic Assembly direct current discbrake	6
	3.3 Function direct current discbrake	6
4	Mechanic Installation	7
	4.1 Before you start	7
	4.2 Preparations	7
	4.3 Installation of motor	8
5	Electric Installation	9
	5.1 Wiring notice	9
	5.2 Operation with frequency inverter	9
	5.3 Switch operation	9
6	Motors and Brakemotors	10
	6.1 General Notes	10
	6.2 Protection	10
	6.3 Cable connections	10
	6.4 Protection against inadmissibly high temperatures	10
	6.5 Protection with motor protection switch only	10
	6.6 Protection with temperature sensors	10
	6.7 Connecting motor	10
	6.7.1 Check cross section	11
	6.7.2 Check winding connections	11
	6.7.3 Temperature sensor	11
	6.8 Connect brake	11
	6.8.1 Note limiting value of switch energy	12
	6.8.2 Ccheck function of brake	12
	6.8.3 Check cross sections	12
	6.8.4 Ambient temperature	12
7	Commissioning	12
	7.1 Conditions for commissioning	12
8	Malfunctions	13
	8.1 Malfunctions motor	13
	8.2 Malfunctions brake	14
	8.3 Malfunctions	14

Contents

issued 03/2022

9	Inspection	15
9.1	Inspection / Maintenance Motor	15
9.2	General Notes	16
9.3	Bearings	16
9.3.1	Bearings with life-time lubrication	16
10	Operating conditions Brake	16
10.1	Installation	17
10.2	Adjustment and checking data	17
10.3	Adjustment of braking torque	17
10.4	Adjustment and regulation of air gap	18
10.5	Subsequent installation of hand lifting	18
10.6	Classification of brake to size of motor	19
10.7	Technical data of brake	19
11	Spare parts	20
11.1	General Notes	20

1 Important Notes

Always follow the safety and warning instructions in this manual!



Electrical hazard

Possible consequences: Severe or fatal injuries.



Hazard

Possible consequences: Severe or fatal injuries.



Hazardous situation

Possible consequences: Slight or minor injuries.



Harmful situation

Possible consequences: Damage to the drive and the environment



Tips and useful information

A requirement of fault-free operation and fulfilment of any rights to claim under guarantee is that you adhere to the information in the operating instructions. Consequently, read the operating instructions before you start operating the drive!

Keep the operating instructions in the vicinity of the unit since they contain important information about servicing the unit.

Waste disposal

This product exists of:

- Iron
- Aluminium
- Copper
- Plastics
- Electronic components

Please dispose of the parts in accordance with the applicable regulations

2 Safety Notes

2.1 The following safety notes apply to the usage of motors

When using geared motors please refer also to the safety notes for gearboxes in the corresponding operating manual

Also please note the additional safety notes in the individual chapters of this operating manual.

All transport, storage, fitting, connection, installation, as well as repair and maintenance works may only be performed by qualified personnel. The following points must be given particular consideration:

- corresponding detailed operating manual(s) and wiring diagrams
- warning labels on motor/geared motor
- system-specific regulations and requirements
- relevant national/regional regulations for safety and accident prevention

Severe damages to persons and property can be caused by:

- inappropriate usage
- faulty installation or handling
- impermissible removal of necessary protective covering or housing.

Designated use

These motors are intended for industrial use; they correspond to the relevant standards and regulations and meet the requirements of the low voltage directive 73/23/EWG.

The technical data and information about the relevant regulations are to be found on the nameplate and in the documentation. All instructions must be strictly observed at all times!

2.2 Transport/Storage

Please check all shipments immediately upon receipt for possible damages in transport. Announce these without delay to the forwarding agent. Start up has to be eliminated if necessary.

Fix screwed transport rings. They are only designed for the weight of the gearbox / geared motor, no additional load can be added.

If necessary use adequate sufficient means of transport. Please remove existing transport securities before start-up.

2.3 Installation/Assembly

Please follow instructions in chapter „Mechanical Installation“!

2.4 Inspection/Maintenance

Please follow instructions in chapter „Inspection/Maintenance“!

3 Assembling



Below drawing has to be understood in principle. It is only to be used as a reference to the spare parts lists. Variations depending on size of motor and type are possible!

3.1 Basic assembly Three-phase motor

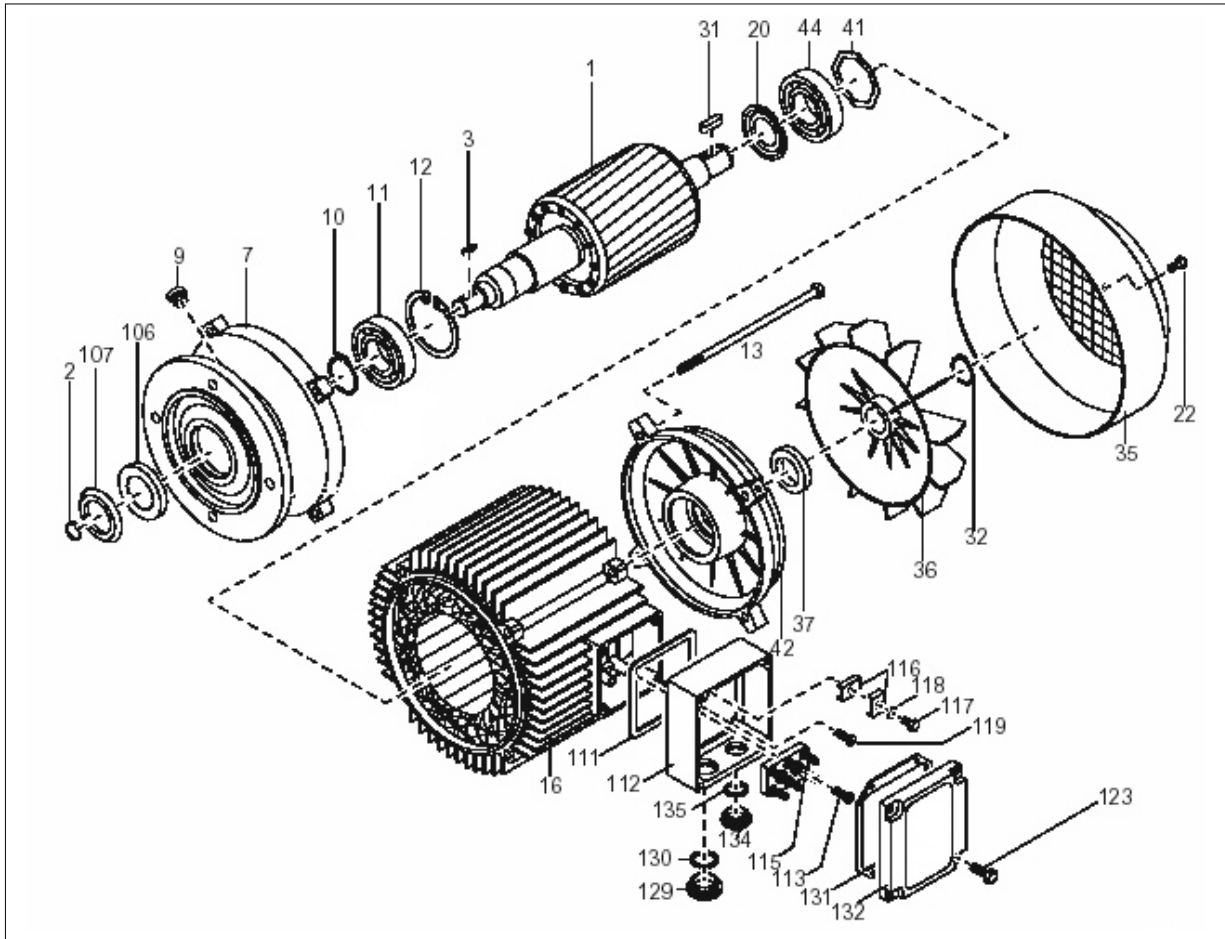

- | | | |
|-------------------------|---------------------------------|----------------------|
| 1 Rotor, cpl. | 41 Equalizing ring | 131 sealing |
| 2 Circlip | 42 Non drive-end bearing shield | 132 Terminal box lid |
| 3 Key | 44 Grooved ball bearing | 134 Screw plug |
| 7 Flanged end shield | 106 Shaft sealing | 135 Sealing |
| 9 Screw plug | 107 Oil-flinger ring | |
| 10 Circlip | 111 gasket | |
| 11 Grooved ball bearing | 112 Terminal box lower part | |
| 12 circlip | 113 Machine screw | |
| 16 Stator, cpl. | 115 Terminal board | |
| 20 Nilosring | 116 Terminal yoke | |
| 22 Hex head bolt | 117 Hex head bolt | |
| 31 key | 118 Lock washer | |
| 32 Circlip | 119 Machine screw | |
| 35 cowl | 123 Hex head bolt | |
| 36 fan | 129 Screw plug | |
| 37 V-Ring | 130 Sealing | |

3.2 Basic assembly DC disc brake

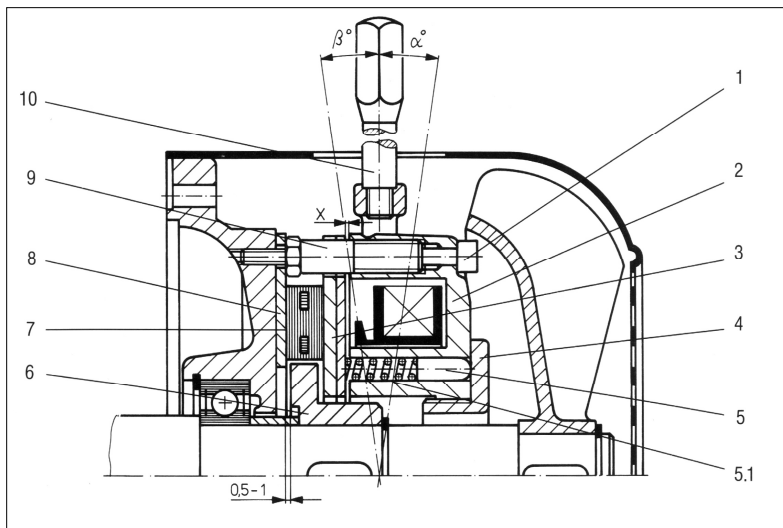

3.3 Function of DC disc brake

At zero current the springs (5.1) press the armature plate (3) and the friction plate (7) against the attachment surface. The friction plate (7) is torsionally secure; yet connected axially movable with the hub (6), The hub is firmly mounted on the shaft, thereby locking it.

After applying the voltage, the DC coil produces a magnetic field in the magnet (2) which attracts the armature plate (3) against the spring force thereby the brake lining (7) is released and allows the shaft to rotate.

The brake is fixed with the fixing screws (1). The air gap is adjusted with screws (1) loosened and with zero current by means of a feeler gauge to the nominal size "X" according to table. After a uniform adjustment the screws are tightened and the brake is ready to operate.

The abrasion caused by dynamic braking results in an enlargement of the air gap. The function of the brake can only be granted by regular control and readjustment when air gap "X" is reached. The minimum permissible friction thickness „g“ must at no times be under-run. The distance of 0.5 ... 1 mm to the attachment surface indicated in the drawing was chosen with respect to a possible shaft play. Through this measurement a dragging of the hub against the mounting surface can be avoided.

A hand release can be mounted to the brake subsequently. Important here is the assembly dimension "m". A wrong adjustment can cause the loss of the braking effect, especially when the brake torque is reduced or the magnet is energized by over voltage.

Ex factory the brake is set at the nominal value. Turning the adjustment nut (4) decreases the brake torque as shown in drawing, at the same time switching times will change accordingly.

When brakes BR07 through BR10 are mounted vertically lifetime of brakes at high speeds

($n > 1500$ 1/min) can be prolonged by using a special lining system. Please contact our sales specialists.

Friction faces have to be free of grease and oil!

4 Mechanic Installation



Please follow the safety instructions in **chapter 2** when installing

4.1 Before you start

The drive may only be fitted when

the information on the nameplate of the drive corresponds with the mains voltage respectively the output voltage of the frequency inverter.

The drive is not damaged (no damage by transport or storage)

The following requirements are achieved:

- Ambient temperature between -25 °C and $+40\text{ °C}$
- No oil, acids, gas, vapours, radiation etc.
- Altitude of site max. 1000 m above NN
- Note restrictions for encoders
- Special version: drive according to environmental conditions

4.2 Preparations

Ends of motor shafts must be completely free of anti-corrosion agents, contamination or other impurities. Do not let solvent get in contact with bearings or seals – danger of damage of the material!

Storage Motors



Please consider shorter working life of ball-bearing grease after extended storage periods more than 1 year.

- Check if motor gathered moisture by extended storage. Check insulation resistance for this purpose (measuring voltage 500 V).

Insulation resistance depends highly on temperature. If insulation resistance is not sufficient motor has to be dried

Drying of Motor

Warm up Motor

- with hot air or
- by isolation transformer

Stop drying when minimum insulation resistance is exceeded.

Check terminal box, if

- interior is dry and clean
- fitting and fixing parts are free of corrosion
- joint seals are correct
- cable connections are tight, otherwise clean or replace

4.3 Installation of Motor



The motor respectively geared motor must only be installed in stated version on a flat, shock free and torsion tight surface.

Align motor and working machine thoroughly, so that output shafts will not be loaded inadmissibly. (Please note allowed lateral and axial forces).

Make sure no shock or eccentricity on shaft ends.

Protect vertically mounted types from penetration of fluid or alien bodies by covering (protection cover).

Cooling air inflow has to be unobstructed, and outgoing cooling air of other units must not be taken in again.

Balance parts which are drawn on shaft later with half key (motor shafts are balanced with half key).

Existing condensation drain holes are sealed and may only be opened when necessary. The condensation drain holes must generally be kept sealed in order to maintain the specified IP protection class.

When using pulleys only belts that do not load electrostatically may be used.

When using brake motors with manual airing screw in either hand lever (for reversing hand airing) or tapped bolt (for fixed hand airing)

Installation in damp locations

Terminal box should possibly be fixed so that cable entries are positioned downwards

Coat threads of cable connections and glands with sealant and fasten tightly – then coat again

Seal cable entries well

Clean sealing faces of terminal box and terminal box cover well before reassembly. Seals have to be glued one-sided. Replace embrittled seals.

If necessary replace corrosion protective coating.

Check enclosure

Tolerances on assembling

Shaft end

Diameter tolerance according to DIN 748

- ISO k6 at $\varnothing \leq 50$ mm
- ISO m6 at $\varnothing > 50$ mm
- centre bore according to DIN 332, Form DR..

Flanges

entering edge tolerance according to DIN 42948

- ISO j6 at $\varnothing \leq 230$ mm
- ISO h6 at $\varnothing > 230$ mm

5 Electrical Installation



It is essential to comply with the safety notes in chapter 2 during installation

Consider additional notes

In addition to general instructions for electric installation of low-voltage equipment (for example DIN VDE 0100, DIN VDE 0105 in Germany) it has to be considered

Use wiring diagrams



Connect motors only according to the wiring diagram which is attached to the motor.

Do not connect or start up the motor if this wiring diagram is missing!

5.1 Wiring notes

Protecting brake control systems against interference

Do not route brake cables alongside switch-mode power cables, as otherwise there is a risk of disrupting brake control systems.

Switched-mode power cables include in particular:

Output cables from frequency and servo controllers, converters, soft start units and brake units

Feeder cables for brake resistors and similar options

Protecting motor protection devices against interference

Route separately shielded feeder cables together with switched-mode power lines in one cable

Do not route unshielded feeder cables together with switched-mode power lines in one cable

5.2 Special aspects for operation with a frequency inverter

When motors are powered from inverters you must adhere to the wiring instructions issued by the inverter manufacturer. It is essential to observe the operating instructions for the frequency inverter.

5.3 Special aspects in switching operation

When the motors are used in switching operation, possible interference of the switch-gear must be excluded by ensuring suitable wiring. According to EN 60204 (electrical equipment of machines) motor wirings must have interference suppression to protect the numerical or programmable logic controllers. As it is primarily switching operations that cause interference, we recommend installing protective circuitry in the switching devices.

6 Motors and brake motors

6.1 General notes

These motors are for industrial use. They correspond to valid rules and requirements. The technical data and specification of permissible conditions are to be found on nameplates and in the documentation. All instructions have to be observed strictly!

6.2 Protection class

The motors are supplied ex factory with at least enclosure class IP 54 according to EN 60034.

6.3 Cable connections

Use for cable entry only cable connections which ensure the protection class stated on name plate.

6.4 Protection against unacceptable high surface temperatures

The motors ensure a safe operation under the operation conditions stated on the name plate. The motors must be provided with overload safety device to prevent unacceptable high temperatures.

Stop can be made with motor protection switch or thermistor temperature sensor.

6.5 Protection with motor protection switch only

When installation is made with motor protection switch according to EN60947 please note:

- The motor protection switch must stop immediately in the event of phase failure
- The motor protection switch must be set to the nominal motor current according to name plate
- For pole-changing motors each pole has to be provided with motor protection switches protected against each other

6.6 Protection with thermistor temperature sensor

Please follow the operating instructions for installing thermistor temperature sensors

6.7 Connect motor



Please follow strictly the valid wiring diagram. Do not connect or start up the motor if this wiring diagram is missing!

6.7.1 Check cross sections

Check cross sections of lines as to nominal current of motor, effective installation rules and requirements in site.

6.7.2 Check winding connections

Check winding connections in terminal box and fasten if necessary

6.7.3 Temperature sensors

Connect temperature sensors according to manufacturer's instructions and attached terminal diagram with lines separated from mains cable.

6.8 Connect brake

The magnet coil has to be connected to the DC voltage. For connection to the AC mains various rectifiers are available. Connection of these rectifiers is shown on below pictures.

For AC side switching the switching contact of the rectifier is bridged.

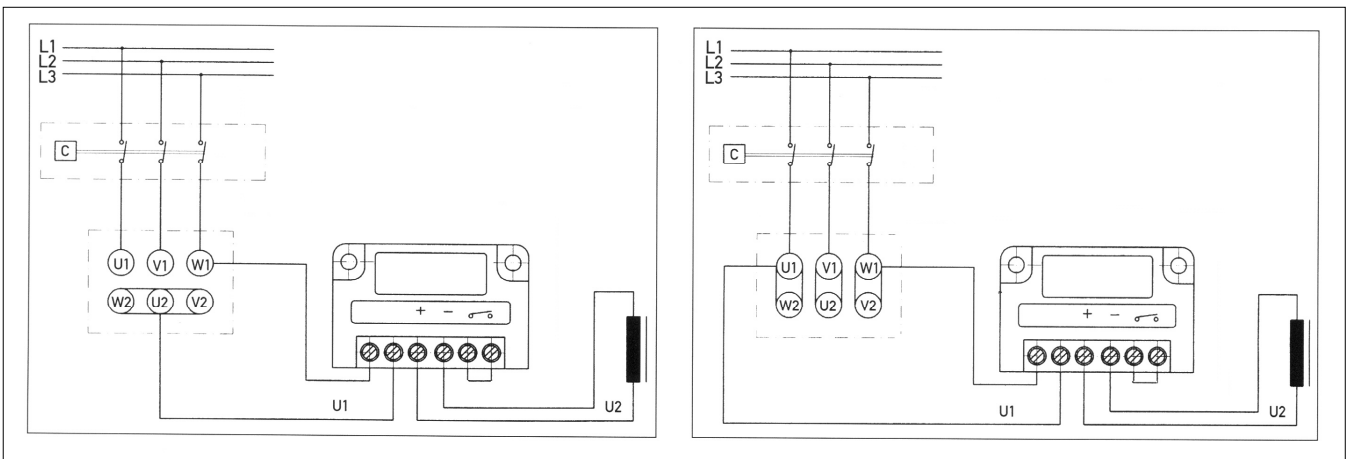

For DC-side switching the switch contact is switched.

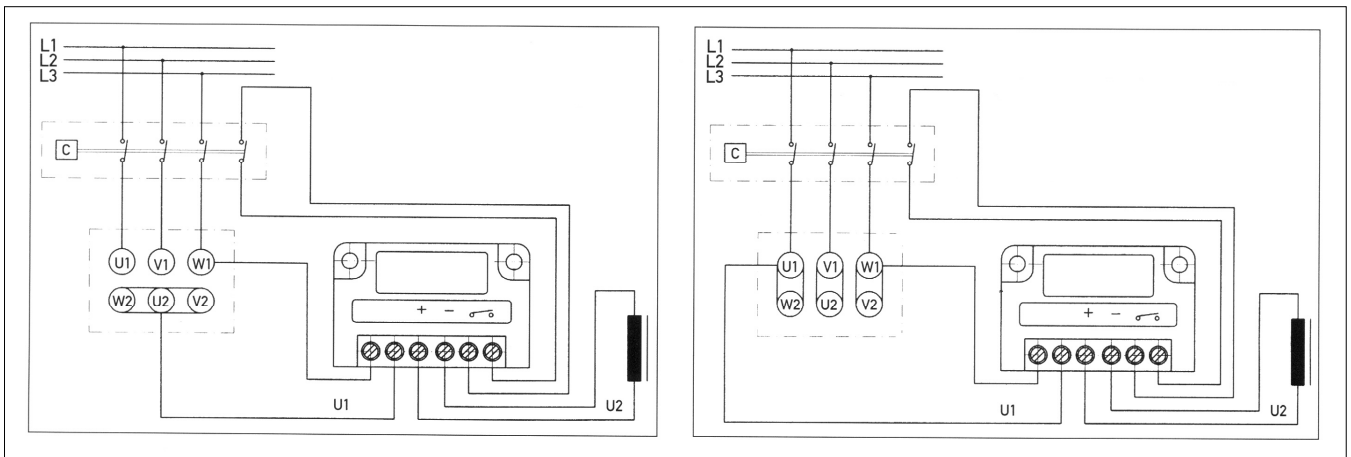

6.8.1 Consider limits of permissible switching operations

The limits of the permissible switching operation have to be considered strictly.

6.8.2 Check function of brake

Before starting check that the brake is in proper working order, so that grinding of brake lining and therefore impermissible heating is avoided. Motor must not start against closed brake. Configure the wiring so that brake is aired before the motor is switched on.

vermeiden. Der Motor darf nicht gegen die geschlossene Bremse anlaufen.

Schaltung so ausführen, dass zuerst die Bremse gelüftet und dann erst der Motor eingeschaltet wird.

6.8.3 Check cross sections

Cross sections of connection lines must be measured appropriate to grant proper function of brake.

6.8.4 Ambient temperature

The performance stated refers to the operating mode stated on the name plate and a max. ambient temperature of 40°C and an altitude of site up to 1000 m above sea level.

7 Starting

7.1 Requirements for starting



Please follow strictly the safety instructions in **chapter 2**

Make sure before starting that

- The drive is not damaged and not blocked
- After extended storage the instructions according to „preparations“ are to be followed
- All connections are made correctly
- The rotating direction of the motor/geared motor is correct
- All protection covers are installed correctly
- All motor protection devices is active and adjusted to the rated current of the motor
- The returning hand airing is used for lift drives
- No other source of danger is existing

Make sure while starting that

- The motor is running properly (no overload, no fluctuation of speed, noise etc.)
- The corresponding brake torque is adjusted for the respective application

8 Malfunctions

8.1 Malfunction of motor

Problem	Possible cause	Remedy
Motor does not start	Connection interrupted	Check connections, correct if necessary
	Brake not aired	See chapter „malfunction of brake“
	Safety fuse blown	Replace safety fuse
	Motor protection is activated	Check motor protection for correct setting, correct error if necessary.
	Motor protection does not switch, mistake in control	Check motor protection control, correct error if necessary
Motor does not start or only with difficulty	Motor is designed for delta connection but is used in star connection	Correct circuit
	Voltage or frequency diverge much at least during switch-on	Provide better power supply, check cross sections of connecting harness
Motor does not start in star connection, only in delta connection	Torque not sufficient in star connection	Switch on directly if delta inrush is not too great: otherwise use a larger motor or a special version (contact us)
	Contact fault on delta star switch	Rectify fault
Incorrect direction of rotation	Motor connected incorrectly	Swap over two phases
Motor hums and has high current consumption	Brake does not release	See chapter „Brake problems“
	Winding defective	Send motor to a specialist workshop for repair
	Rotor rubbing	
Fuses blow or motor protection trips immediately	Short circuit in line	Correct circuit
	Short circuit in motor	Send motor to specialist workshop for repair
	Lines connected incorrectly	Correct circuit
	Ground fault on motor	Send motor to specialist workshop
Severe speed loss under load	Overload	Perform power measurement, use larger motor or reduce load if necessary
	Voltage drops	increase cross section of connecting harness
Motor heats up excessively (measure temperature)	Overload	perform power measurement, use larger motor or reduce load if necessary
	Inadequate cooling	Correct cooling air supply or clear cooling air passages, retrofit forced cooling fan if necessary
	Ambient temperature too high	Adhere to permitted temperature range
	Use delta connection for motor rather than star connection as provided for	Correct circuit
	Loose contact in connecting harness (one phase missing)	Rectify loose contact
	Fuse blown	Look for and rectify cause (see above), replace fuse
	Supply voltage deviates from rated motor voltage by more than 5%. A higher voltage has a particularly unfavourable effect in these, the no-load current is already close to the rated current even when the voltage is normal	Adapt motor to supply voltage
	Rated operation type (S1 to S10, DIN 57530) exceeded, e.g. through excessive starting frequency.	Adjust rated operation type of motor to required operating conditions; if necessary call in a specialist to determine correct line
Excessively loud	Ball bearing compressed, contaminated or damaged	Re-align motor, inspect ball bearing, grease if necessary replace
	Vibration of rotating parts	Rectify cause, possibly imperform power measurement, use larger motor or reduce load if necessary
	Foreign bodies in cooling air passages	Clean the cooling air passages

8.2 Brake problems

Problem	Possible cause	Remedy
Brake does not release	Incorrect voltage on brake control unit	Apply correct voltage
	Brake control unit failed	Install a new brake control system, check internal resistance and insulation of brake coil, check switchgear
	Max. permitted working air gap exceeded because brake lining worn down	Measure and set working air gap
	Voltage drop along connecting harness >10%	Provide for correct connection voltage; check cable cross
	Inadequate cooling, brake overheats	Replace brake rectifier
Motor does not brake	Brake coil has winding fault or short circuit to exposed conductive part	Replace complete brake and brake control system (specialist workshop), check switchgear
	Working air gap not correct	Measure and set working air gap
	Brake lining worn down	Replace entire brake disc
	Incorrect braking torque	Change the braking torque
Brake is applied with time lag	Hand release not set correctly	Set the setting nuts correctly
	Brake is switched on AC Voltage side	Switch on DC and AC voltage sides, please refer to wiring diagram
Noise in the brake area	Gearing wear caused by jolting startup	Check project planing
	Pulsating torques due to incorrectly set frequency inverter	Check/correct setting of frequency inverter according to operating instructions

8.3 Malfunctions during operation

The symptoms described in the „Motor Malfunctions“ section may also occur when the motor is operated with a frequency inverter. Please refer to the frequency inverter operating instructions for the significance of the problems which occur and to find information about rectifying the problems.

Please have the following information to hand if you require the assistance of our customer service:

- Data from the name plate (complete)
- Nature and extend of the problem
- Time and peripheral circumstances of the fault
- Presumed cause

9 Inspection



Use only genuine spare parts in accordance with the valid spare parts list!
 Always install a new brake control system at the same time as replacing to brake coil!
 Motors can become very hot during operation – danger of burns!
 Secure hoist drives or lower them (danger of falling).
 Isolate the motor and brake from the supply before starting work, safeguarding them against unintentional power-up!

Unit / unit part	Frequency	What to do?
Brake	If used as a working brake: At least every 3000 hours of operation	Inspect the brake Measure the brake thickness Brake disc, lining Measure and set working air gap Pressure plate Carrier/gearing
Motor	Every 10,000 hours of operation	Inspect the motor: Check ball bearings and change if necessary Change oil seal Clean the cooling air passages
Tachogenerator, Encoder		Inspektion / Wartung gemäß zugehöriger Betriebsanleitung

The periods of wear are affected by many factors and may be short. The machine designer must calculate the required inspection/maintenance intervals in accordance with the project planning documents.

9.1 Inspection / maintenance Motor



Isolate the motor and brake from the supply, safeguarding them against unintentional power-

Basic procedure:

1. Remove the forced cooling fan and encoder, if installed
2. remove flange or cowl and fan
3. Remove the screws from the drive-end bearing end shield and the non-drive-end bearing end shield, release stator from drive-end bearing end shield, lift non-drive-end bearing end shield with motor shaft carefully off the stator.

Motors with brake

4. open the terminal box lid, unfasten the brake cable from the rectifier
Release brake from non-drive end bearing end shield
Remove the complete brake with the releasing lever (on version with manual brake release)
5. Visual inspection: Are there traces of gear oil or condensation inside the stator?
 - if not, continue with 9
 - if there is condensation, continue with 7
 - if there is gear oil, have the motor repaired by a specialist workshop
6. If there is moisture inside the stator:
 - with gearmotors: remove the motor from the gear unit
 - with motors without gear unit: remove the drive end flange
 - Remove the rotor.
7. Clean the winding, dry it and check it electrically
8. Replace the ball bearings
9. Replace the shaft seal in the drive end bearing shield
10. Reseal the stator seat and grease V-ring or labyrinth seal
11. Install the motor, brake and accessories
12. Check the gear unit

9.2 General notes

Depending on degree of spoiling the motors must be cleaned routinely over their full surface e.g. using dry compressed air.

The first inspection must be executed normally after approx. 500 operating hours, after 1 year at the latest. Follow-up inspections should, depending on the conditions of use, be executed at appropriate intervals, such as re-greasing and grease change intervals, but at least once a year

During inspections it must be checked that:

- the technical data specified on the nameplate are kept,
- no leakages (oil, grease, water) exist
- the running noise of the bearings and the smoothness of the motor have not deteriorated,
- all fastening bolts for electrical und mechanical connections are safe,
- the alignment of the motor lies within the allowable tolerances during coupling operation.

9.3 Bearings

9.3.1 Bearings greased for life-time

The bearings of the motors with life-time lubrication are maintenance free under normal operation conditions for 10,000 to 20,000 operating hours, but for no longer than 3 years.

For motors which have bearings sealed by two caps (2Z bearings) and with speeds up to 3,600 rpm the bearings should be replaced after 20,000 operating hours, after 3 years at the latest.

For motors sealed by a single cap (Z bearing) or a single bearing end cap the grease must be replaced

- After 20,000 operating hours for speeds up to 1 800 rpm
- After 10,000 operating hours for speeds up to 3 600 rpm

After 3 years at the latest, grease and bearings if necessary have to be replaced.

10. Operating conditions brake

Before installing the spring-loaded brake observe the following:

1. Provide a suitable 2nd friction ring. Plane friction surfaces made from cast iron or steel. The surface roughness R should not exceed 25 pm. Avoid sharp-edged interruptions in the friction surface. If such a surface is not available a friction disc or flange can be used optionally (available as accessories)
2. The eccentricity of the mounting hole circle to the shaft end shall not exceed the following values: size 00 ... 02 0.2mm; size 03 ... 06 0.4mm; size 07..10 0.5mm.
3. The angular deviation of the mounting surface to the shaft shall not exceed the following values: size 00 ... 03 0.04mm; size 04 and 05 0.05mm; size 06 and 07 0.06mm; size 08 ... 10 0.08mm (in reference to the bolt diameter).
4. The friction surfaces must be free from grease and oil.
5. Humidity, aggressive fumes and similar means can cause the rusting in of the friction lining. In such cases rustproof friction discs are optionally available.
6. The movement of the armature shall not be obstructed by foreign bodies penetrating into the nominal air gap. If necessary the protective rings (optionally) are to be used or other protective measures are to be taken.

10.1 Installation

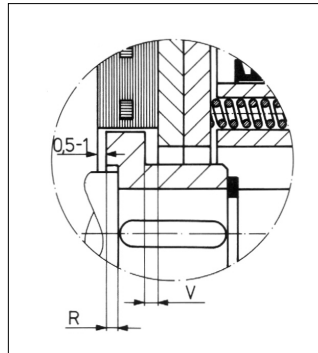

1. Mount the hub on the shaft and secure it axially. Absolutely avoid any damage to the hub and make sure that the hub cannot run against the 2nd friction surface. Considering the axial play of the shaft we recommend a distance of 0,5 ...1 mm.
2. Slide the friction ring on the hub. Be careful not to damage the friction lining through misaligned or tilted attachment (The lining must slide easy on the hub)
3. Attach the magnetic system (completely assembled) with head cap screws in doing so adjust the nominal air gap „X“ with a feeler gauge or by means of the adjustment spacers At that the brake must be in the power off mode. We recommend screws of the strength class 8.8 which should be tightened with the torque recommended by the manufacturers.

10.2 Setting and checking data

Size	Nominal air gap X [mm]	Max. permissible wear V [mm]	Readjsutumt necessary at Xn [mm]	Min. permissible lining thickness g min [mm]	R [mm]	m [mm]
BR02	0,2	2,0	0,4	5,5	0,5	0,8
BR03	0,2	1,5	0,5	6,5	1,5	1,0
BR04	0,2	2,5	0,6	8,0	1,5	1,4
BR05	0,2	2,0	0,6	10,0	2,0	1,5
BR06	0,3	2,0	1,0	10,0	2,0	1,8
BR07	0,3	4,0	1,0	10,0	-	2,0
BR08	0,4	5,0	1,2	11,0	-	2,0
BR09	0,4	6,0	1,2	12,0	-	2,3
BR10	0,5	8,0	1,5	14,0	-	2,7

10.3 Adjustment of braking torque

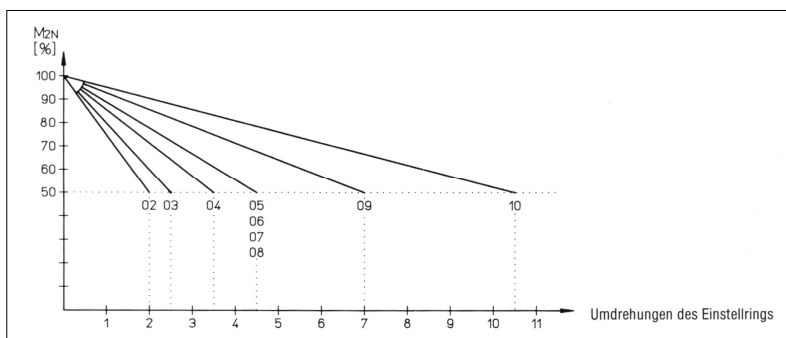

The braking torque is adjusted to the rated torque in the factory. It can be changed by turning the adjustment ring. Above figure shows the approximate torque change. By changing the adjustment ring a change of the switching times is caused!

10.4 Re-adjustment of clearance

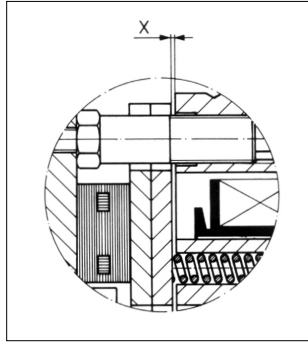

The normal air gap becomes larger due to wear. To guarantee a trouble-free function the air gap should be readjusted when the air gap „X“ is reached. To do that, disconnect the brake from load to avoid an uncontrolled motion of rotation

1. Loosen the head cap screws.
2. Adjust the air gap by turning the adjustment spacers. Please note that the adjustment is uniform at all points.
3. Tighten the head cap screws again.
4. Check the air gap again and repeat the procedure if necessary.
5. This procedure can be repeated as often as needed until the friction lining has reached the minimum permissible thickness „g“. The friction lining and friction surfaces must be renewed and refinished.

10.5 Subsequent attachment of hand release

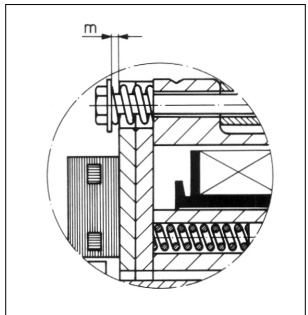

Push the screws with disks and springs through the provided bores into magnet and armature disk. Attach the hand release bracket and tighten it with self-locking nuts. The alignment dimension „m“ must be adjusted with attracted armature. The dimension „m“ applies to rated torque and operation with rated voltage. Please contact us in case of different operating conditions

10.6 Classification of brake to size of motor

Motor frame size	Motor extension	Type							
		BR02	BR03	BR04	BR05	BR06	BR07	BR08	BR09
IEC	[mm]	Brake torque [Nm]							
		5	10	20	40	60	100	150	250
56	43	X							
63	60	O	X						
71	60	O	X	X					
80	67	X	O	X					
90	75		X	O	X				
100	90		X	X	O	X			
112	95		X	X	X	O	X		
132 S	108				X	O	X	X	
132 M	108				X	X	O	X	
160	129					X	X	X	X
180	145					X	X	X	X

O=Standard size classification

10.7 Technical data brakes

Type		BR02	BR03	BR04	BR05	BR06	BR07	BR08	BR09
Brake torque	MBr (Nm)	5	10	20	40	60	100	150	250
Max. Speed	(1/min)	6000	6000	6000	6000	3600	3600	3600	1800
Coil rating	Ps (W)	22	28	34	45	55	85	76	105
Weat load	Prmax (J/S)	80	100	130	160	200	250	300	350
Friction work per operation	Wrzul (J)	1500	3000	6000	12500	17500	25000	37500	52500
Friction until 0,1 mm wear is reached	WRx10 ⁶ (J)	16	30	42	70	85	140	170	230
Moment of inertia	J x10 ⁻³ (kgm ²)	0,015	0,045	0,173	0,45	0,86	1,22	2,85	6,65
Air gap	x (mm)	0,2	0,2	0,3	0,3	0,3	0,4	0,4	0,5
Max. permissible wear	(mm)	2,0	1,5	2,5	2,0	2,0	4,0	5,0	6,0
Readjustment at	(mm)	0,6	0,7	0,8	0,9	1,0	1,1	1,1	1,2

11 Spare parts

11.1 General notes

When ordering spare parts please always state the motor type and motor number (data to be found on the name plate) additional to the exact parts description.

With the exception of standardised commercially available and equivalent parts e.g. bearings only original parts must be used.

This applies in particular to seals and connecting terminals.