

Operating Instructions

Gearboxes
Types SR, FG, S, SS, SM(N), SSM

Three-phase motors
Size 50 - 315



Rehfuß Drive Solutions GmbH
Vor dem Weißen Stein 21
72461 Albstadt, Germany

Fon +49 (0) 74 32 / 70 15 - 0
Fax +49 (0) 74 32 / 70 15 - 90

E-mail: info@rehfuss.com
Internet: www.rehfuss.com

1	Important Notes	4
2	Safety Notes	5
2.1	Safety notes for standard use	5
2.2	Designated use	5
2.3	Transport	5
2.4	Gearboxes with extended storage	6
2.5	Installation	6
2.6	Start up	6
2.7	Inspection / Maintenance	6
3	Construction of gearbox	7
3.1	Basic construction helical gear 1-step SR120 – SR160	7
3.2	Basic construction helical gear 2-step SR210 – SR260	8
3.3	Basic construction helical gear 3-step SR320 – SR360	9
3.4	Basic construction helical gear SR270 – SR370	10
3.5	Basic construction shaft mounted gearboxes Type FG	11
3.6	Basic construction worm gearbox S030 – S050 solid shaft	12
3.7	Basic construction worm gearbox S030 – S050 hollow shaft	13
3.8	Basic construction helical worm gearbox SS130 – SS150 solid shaft	14
3.9	Basic construction helical worm gearbox SS130 – SS150 hollow shaft	15
3.10	Basic construction helical worm gearbox SS160 – SS170 solid shaft	16
3.11	Basic construction helical worm gearbox SS160 – SS170 hollow shaft	17
3.12	Basic construction worm gearbox SM011, SM(N)021, SM(N)031 solid shaft / hollow shaft	18
3.13	Basic construction worm gearbox SM041 solid shaft / hollow shaft	19
3.14	Basic construction worm gearbox SM(N)051 – SM061 solid shaft	20
3.15	Basic construction worm gearbox SM(N)051 – SM061 hollow shaft	21
3.16	Basic construction worm gearbox SSM121 – SS131	22
3.17	Basic construction worm gearbox SSM151 – SS161	23
3.18	Basic construction slip clutch	24
3.19	Basic construction IEC – Adapter	25
3.20	Basic construction free input shaft	26
4	Mechanical Installation	27
4.1	Required tools	27
4.2	Before you start	27
4.3	Preparation	27
4.4	Installation of gearbox	28
4.5	Gears with solid shaft	29
4.6	Mounting torque arm	30
4.7	Mounting / dismantling of shaft gearboxes with hollow shaft	30
4.8	Mounting / dismantling of shaft gears with shrink discs and cowl	30
4.9	Mounting IEC – Adapter	31
4.10	Mounting IEC – Adapter with adapter flange	32
4.11	Mounting IEC – Adapter SM041	33
4.12	Mounting on free input shaft	34

Contents

5	Installation	35
5.1	Control lubricant with Oil level screw	35
5.2	Control lubricant on gearboxes without Oil level screw	35
5.3	Starting of worm gearboxes	35
5.4	Starting of helical and shaft mounted gearboxes	35
5.5	Starting gears and geared motors	35
6	Inspection and Maintenance	36
6.1	Inspection and maintenance intervals	36
6.2	Change intervals of lubrications	36
6.3	Change intervals of rolling bearings	36
6.4	Inspection and maintenance gearboxes	38
6.5	Inspection and maintenance IEC – Adapter	38
6.6	Inspection and maintenance free input shaft	38
7	Malfunctions	39
7.1	Malfunction of gearbox	39
7.2	Malfunction of IEC – Adapter	40
7.3	Malfunction on free input shaft	40
8	Types / Mounting positions	41
8.1	General information about mounting positions	41
8.2	Mounting position SR 1-step	42
8.3	Mounting position SR 2-step	43
8.4	Mounting position FG	44
8.5	Mounting position S	45
8.6	Mounting position SS	46
8.7	Mounting position SM(N) / SSM	47
9	Lubricants	48
	Table: Capacity	49
	Table: Lubrications	50

1 Important Notes

Always follow the safety and warning instructions contained in this publication!



Electrical hazard

Possible consequences: Severe or fatal injuries.



Hazard

Possible consequences: Severe or fatal injuries.



Hazardous situation

Possible consequences: Slight or minor injuries.



Harmful situation

Possible consequences: Damage to the drive and the environment



Tips and useful information

A requirement of fault-free operation and fulfilment of any rights to claim under guarantee is that you adhere to the information in the operating instructions. Consequently, read the operating instructions before you start operating the drive!

Keep the operating instructions in the vicinity of the unit since they contain important information about servicing the unit.

Waste disposal

(please dispose of the parts in accordance with the applicable regulations)

parts of housing, gears, shafts and rolling bearings of the gearboxes are to be disposed as iron. Cast parts as well when there is no special collection.

Worm wheels are partly made from non-ferrous materials and are to be disposed of in accordance to applicable regulations.

Collect used oil and dispose of in accordance to applicable regulations.

2 Safety Notes

2.1 Safety notes for standard use

Preliminary remarks

The following safety notes refer mainly to the use of gearboxes. When using geared motors please refer to the safety notes for motors in the corresponding operation instruction.

Also take account of the additional safety notes in the individual sections of these operating instructions.

General

During and after operating geared motors, gearboxes and motors have live and rotating parts as well as possibly hot surfaces. All works to transport, stocking, connection, start up, repair and maintenance may only be performed by qualified personnel under strict consideration of

- these instructions and terminal diagrams
- warning and instruction labels on gearboxes/geared motors
- system-specific regulations and requirements
- national/regional regulations for safety

Severe damages on persons and equipment may result from

- inexpert application
- false installation or use
- not allowed removal of necessary protection covers or housing

2.2 Designated use

These gearboxes / geared motors are intended for industrial systems, they correspond to applicable standards and regulations and meet the requirements of directive 94/9EC (Atex 100a).

Technical data and information to applicable regulations are listed on the nameplate and in the documentation. All instructions must be strictly observed!

2.3 Transport

Please check all shipments immediately upon receipt for possible damaged in transport. Announce these without delay to the forwarding agent. Start up has to be postponed if necessary. Fix screwed transport rings. They are only designed for the weight of the gearbox / geared motor, no additional load must be added. Build in ring screws correspond to DIN 580. Loads and instructions contained therein have to be observed strictly. When two transport rings or ring screws are fixed, transport has to be executed on both transport rings. Direction of draw angle may not exceed 45° according to DIN 580. If necessary use sufficient means of transport. If there are transport securities please remove before start-up.

2.4 Gearboxes with extended storage

Gearboxes with extended storage contain a typical, ready for use oil filling with oil. Please check oil level before start up.

For extended storage please observe stocking conditions as stated below:

package	Place where stored	Storage time
open	Under a roof and closed at constant temperature and humidity (5° -60%, <50% rel. humidity) No sudden changes of temperature and controlled ventilation with filter (free of dirt and dust). No aggressive damp and vibrations. Protect from insects.	2 years and more with regular inspections. Check if clean and mechanical damages. Check if corrosion protection is complete.

Packaging has to be done by experienced personnel with for the usage qualified packing material.

2.5 Installation

Please note information in chapters „installation“ and „Assembly/Dismantle“.

2.6 Start up

Check correct direction when not coupled (listen for unusual grinding noises when turning). For test running without driving elements protect feather .Do not turn off control and protection functions even for tests. When there are changes to regular use as there are rise of temperature, noise, vibrations) geared motor has to be stopped. search reason , if necessary contact REHFUSS.

2.7 Inspection / Maintenance

Note information in chapter „inspection / maintenance“!

3 Construction of gearbox

3.1 basic construction helical gear 1-step SR120 – SR160

version L,C,B,F,Z

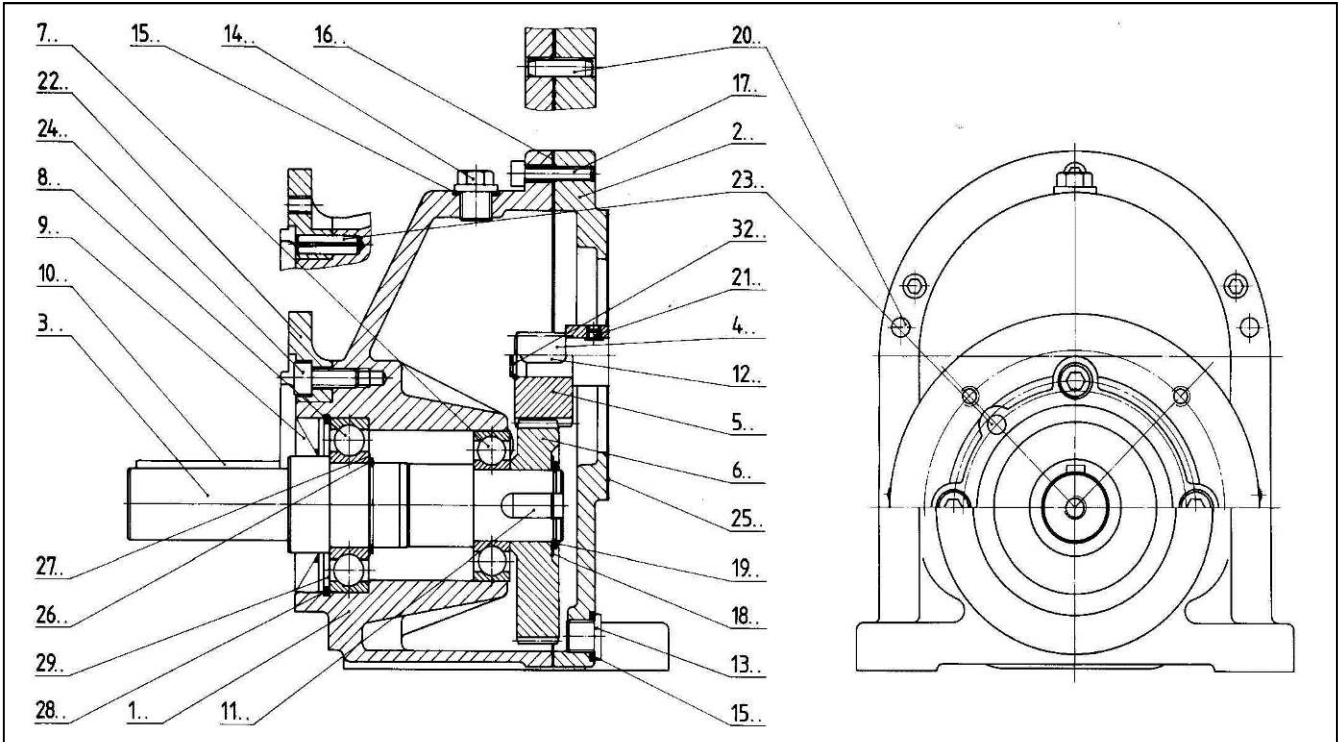

version R

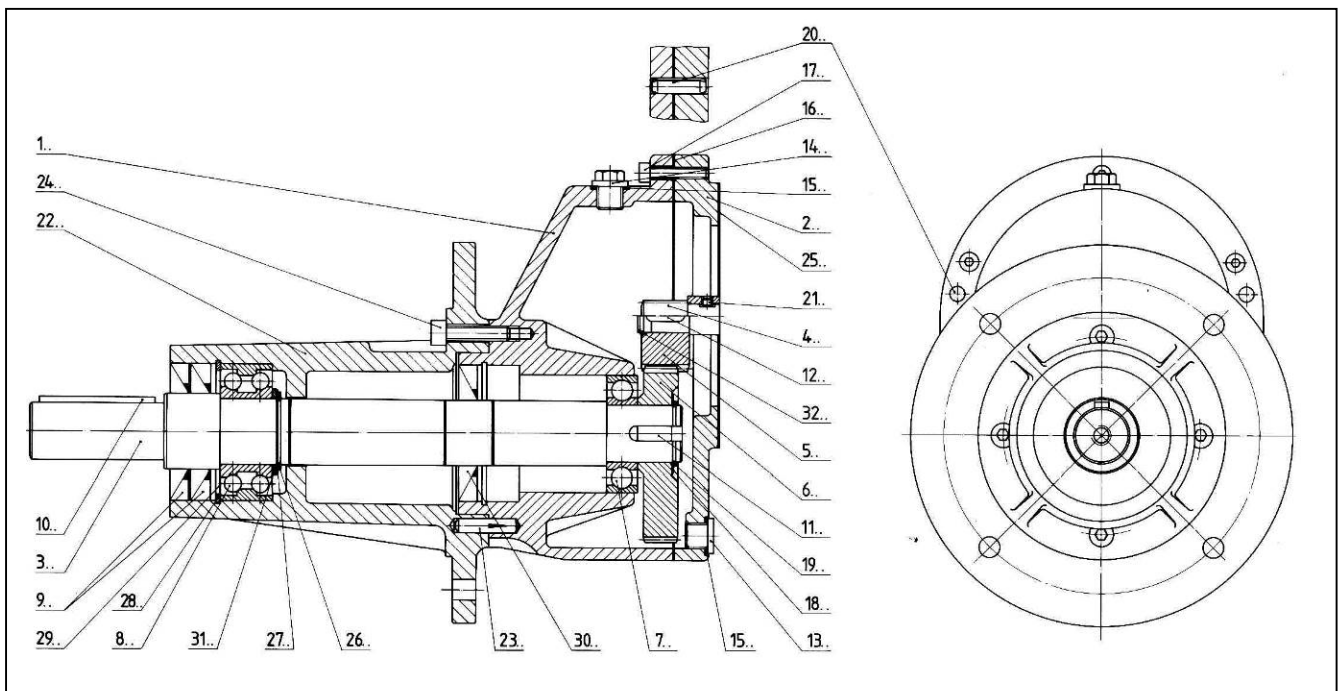

3.2 Basic construction helical gear 2 step SR210 – SR260

version L,C,B,F,Z

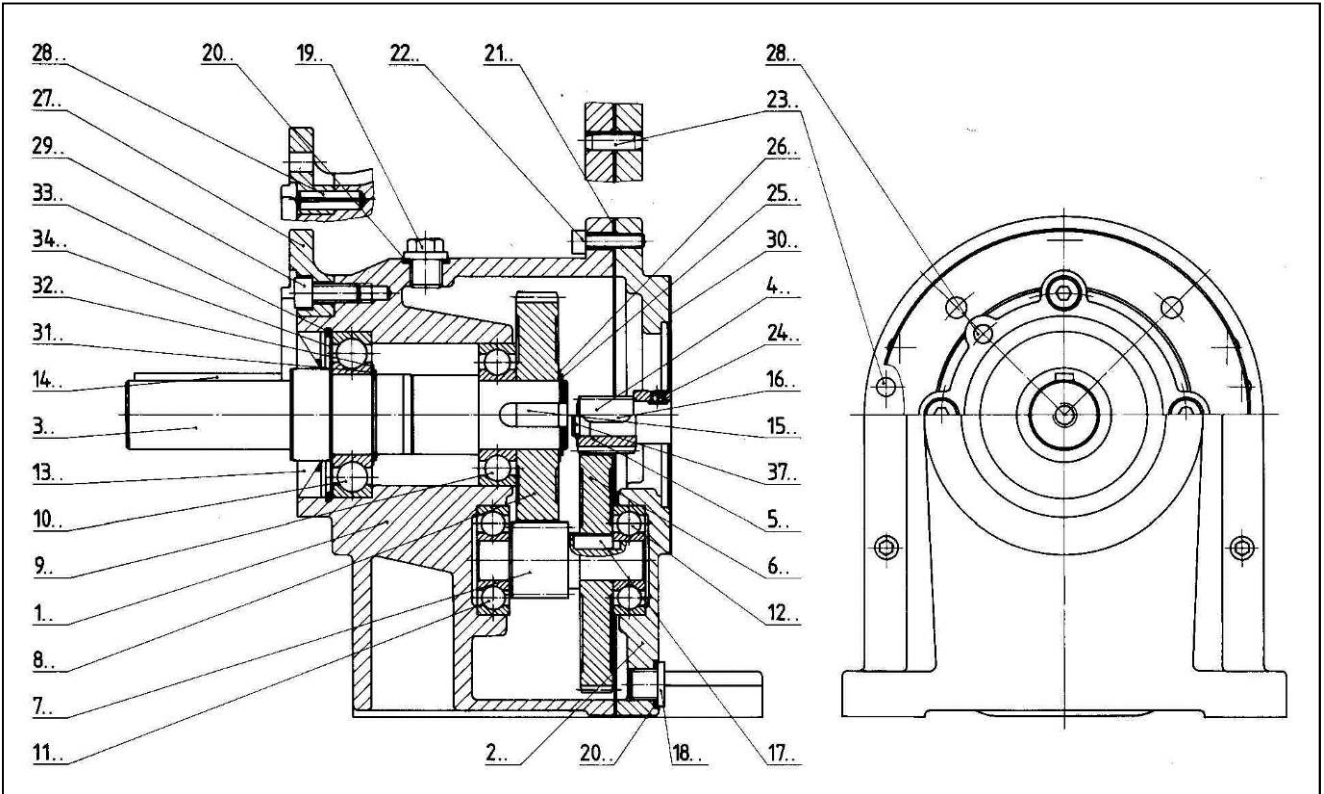

version R

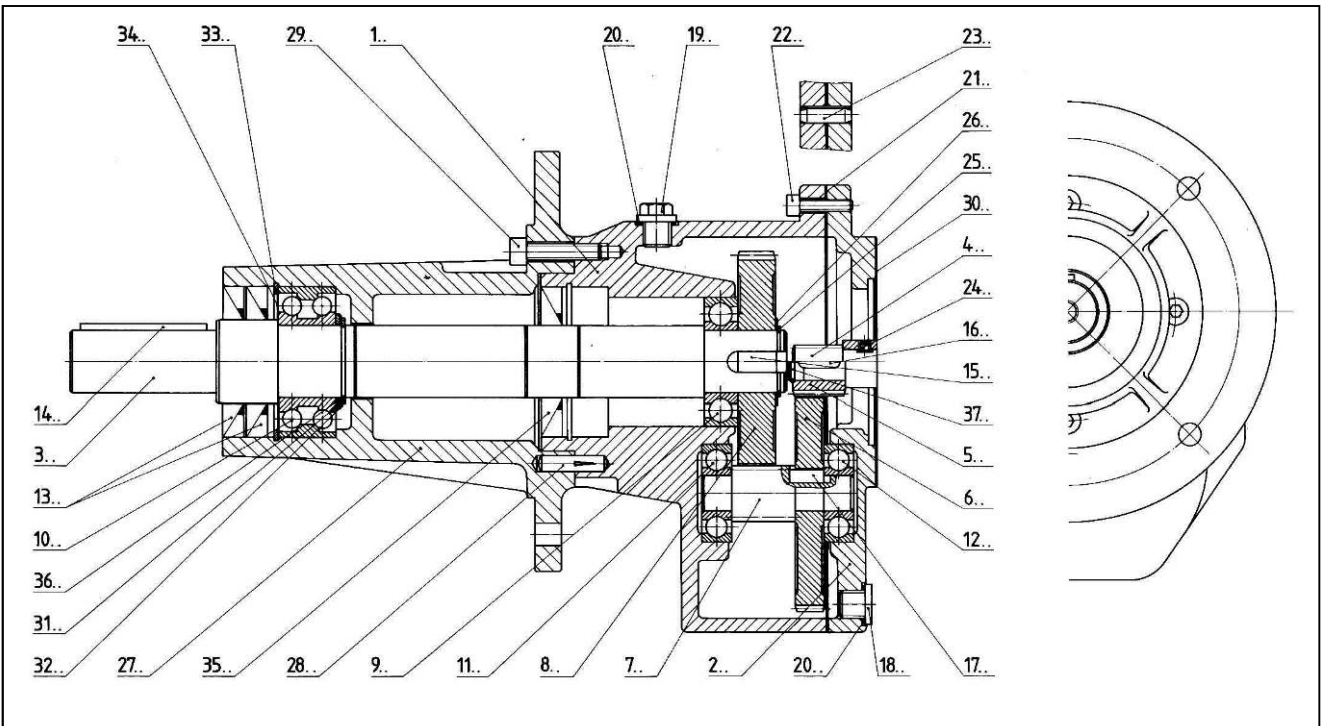

3.3 Basic construction helical gear 3-step SR320 – SR360

version L,C,B,F,Z

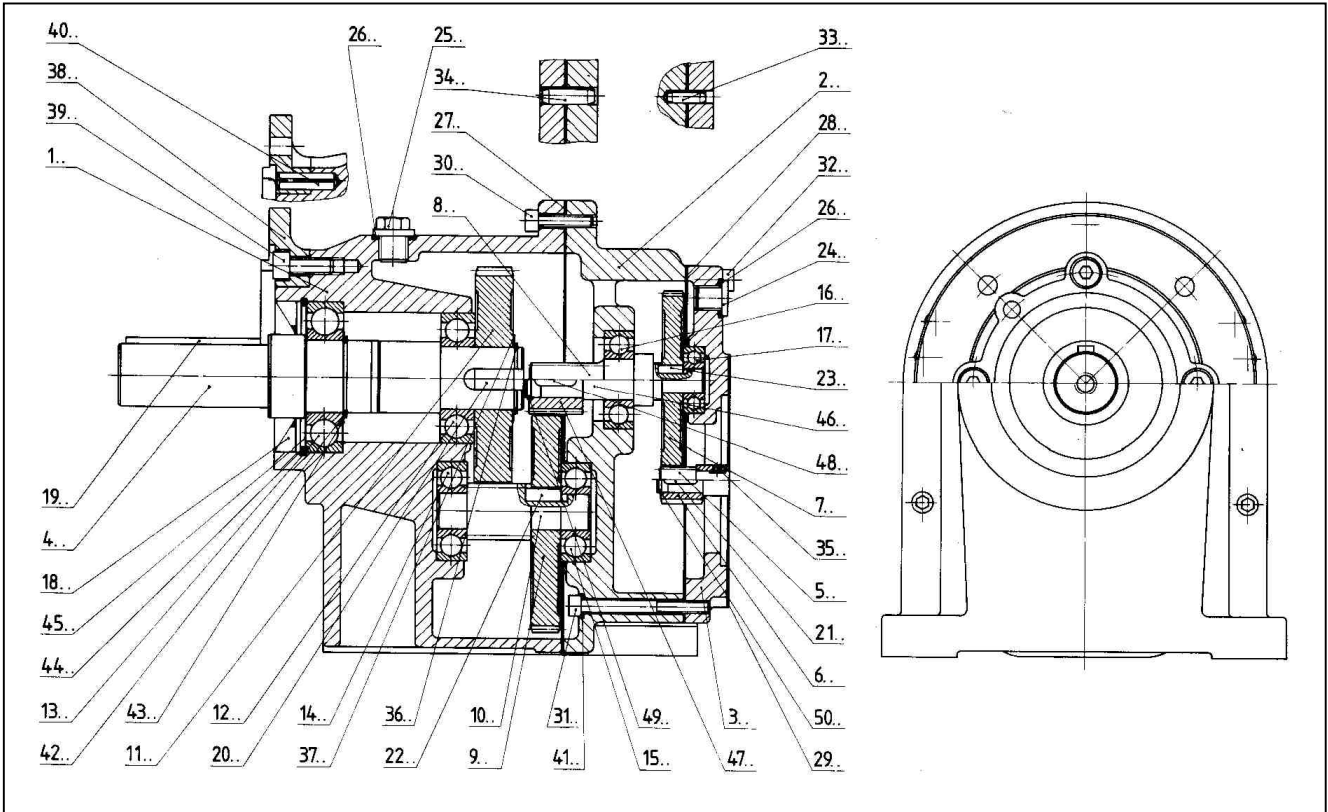

version R

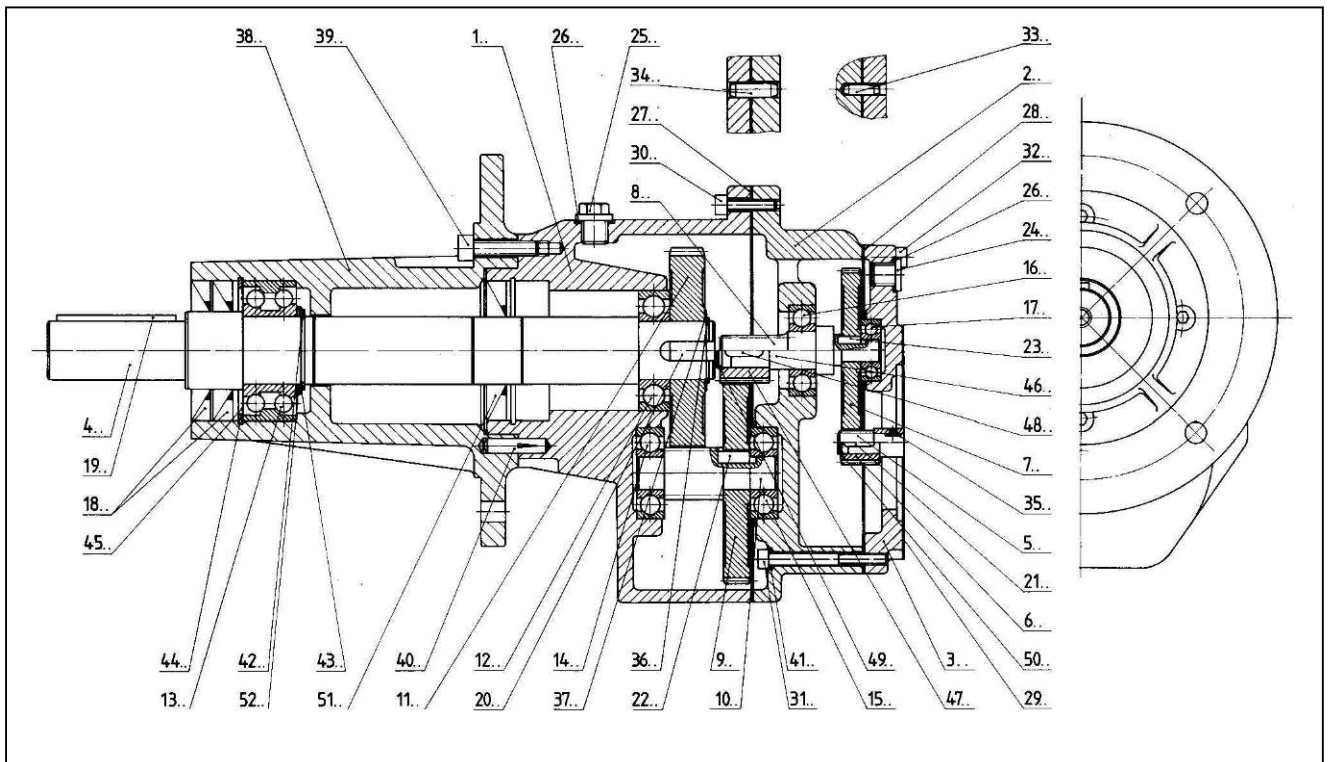

3.4 Basic construction helical gear SR270 – SR370

version L,B,F

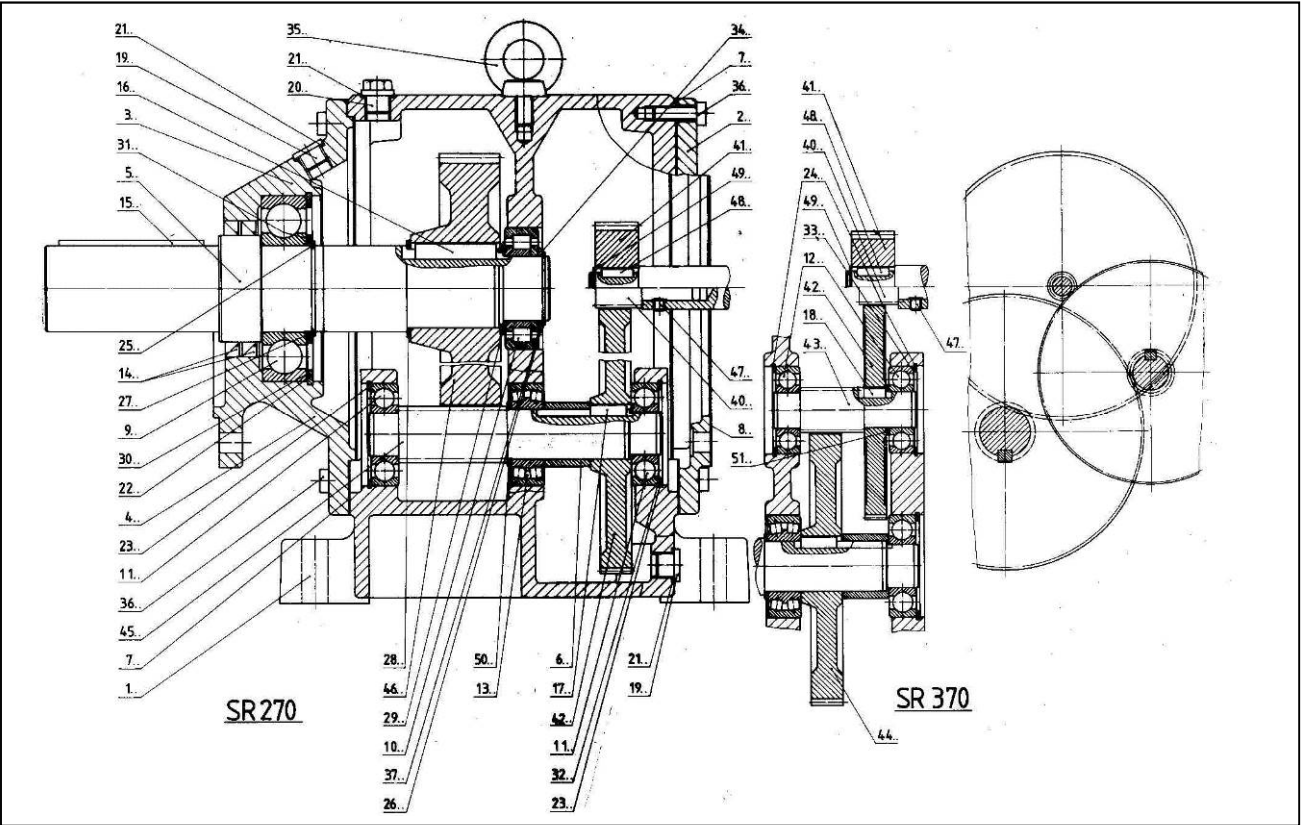

version R

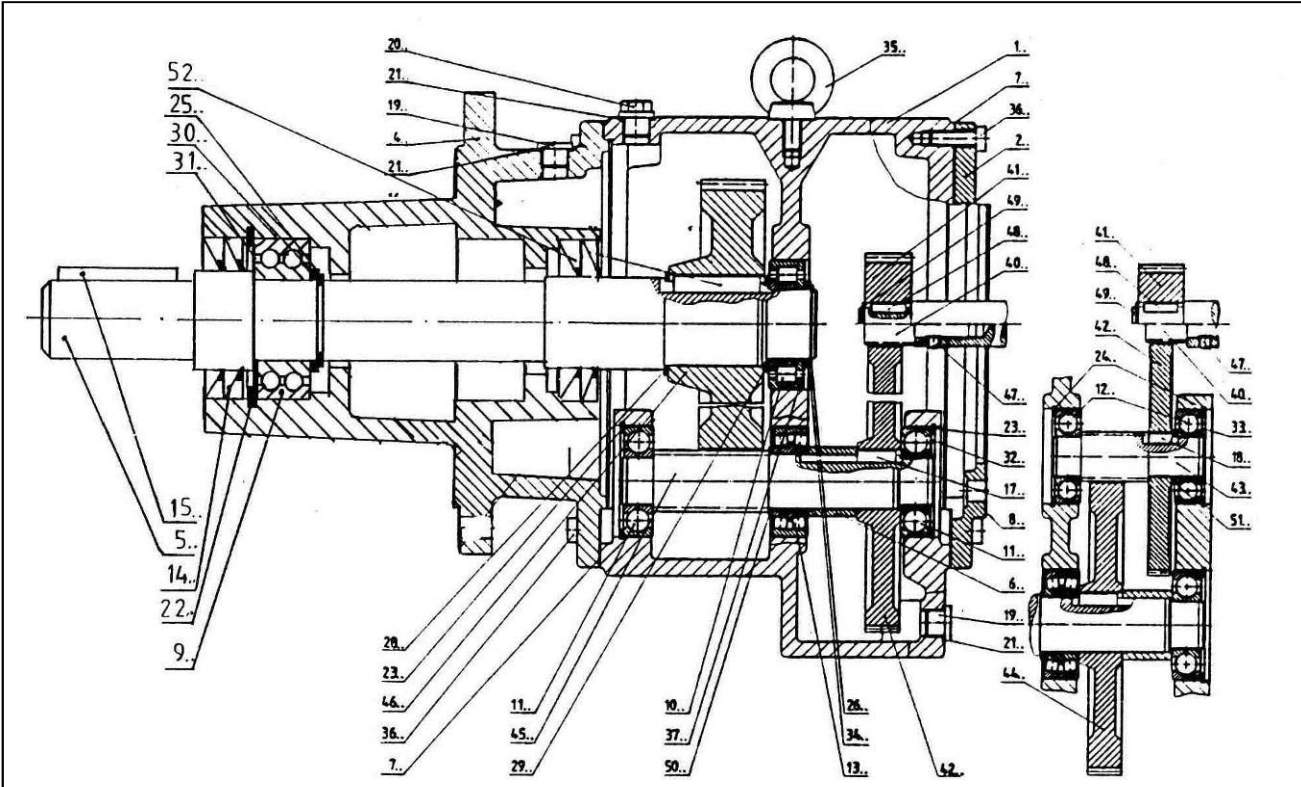

3.5 Basic construction shaft mounted gearboxes Type FG

version WG,WF,WU

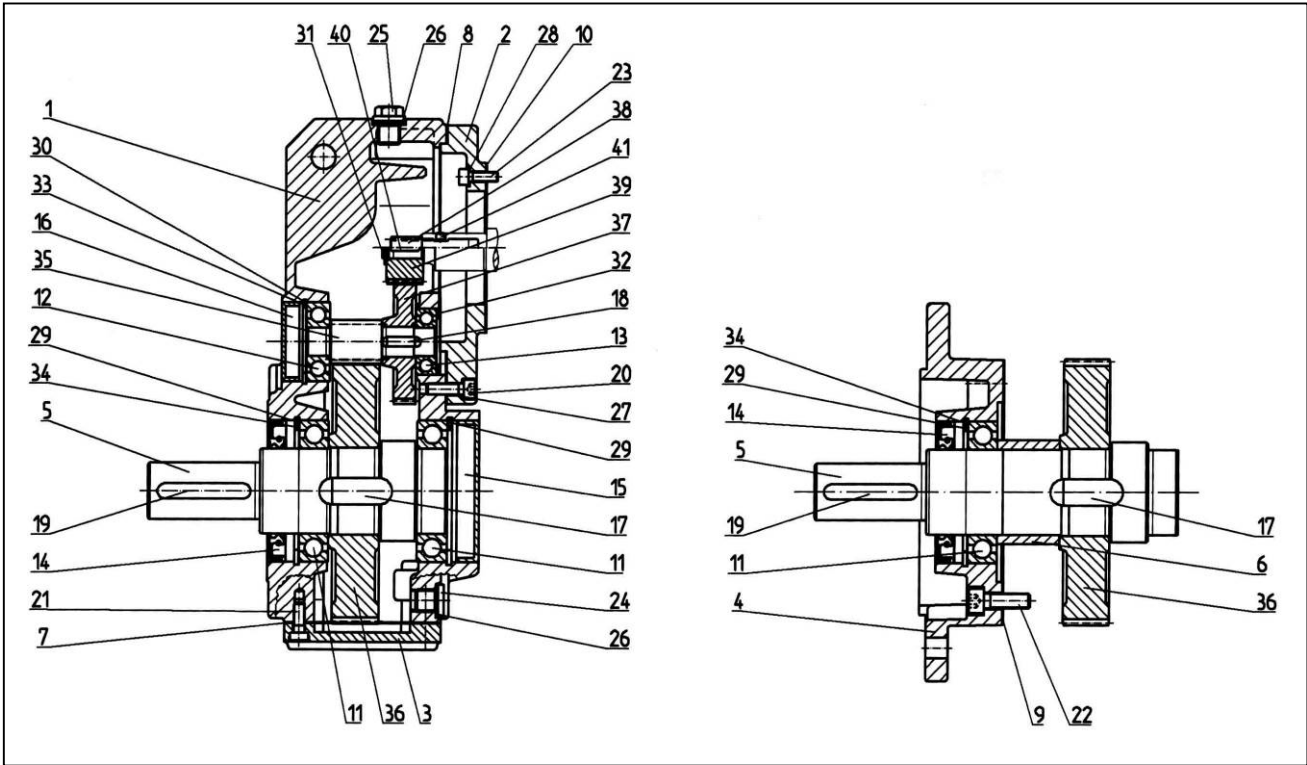

version HG, HF, HU

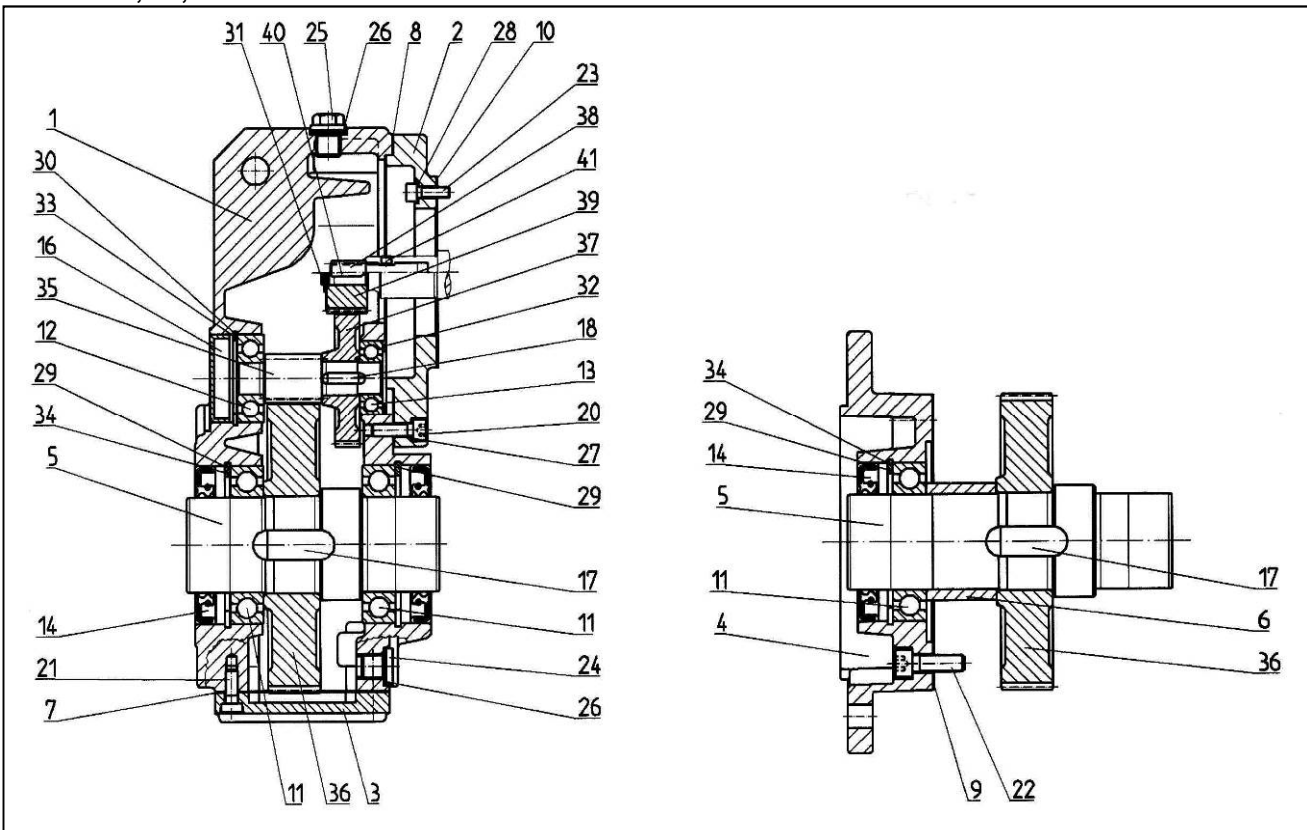

3.6 Basic construction worm gear box S030 – S050 IEC, K, KF

version WG,WF,WL,WD

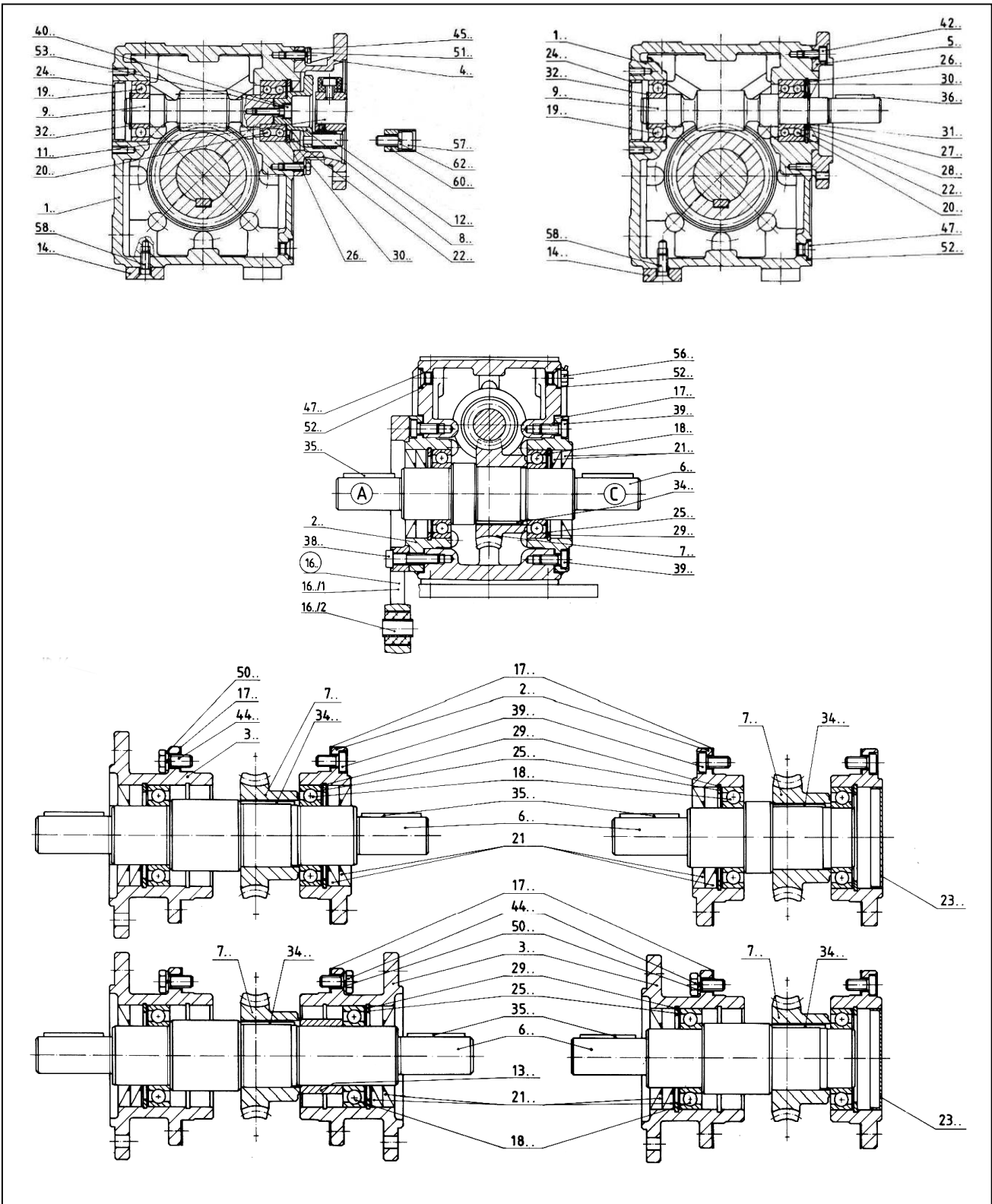

3.7 Basic construction worm gear box S030 – S050 IEC, K, KF

version HG, HF, HL, HD

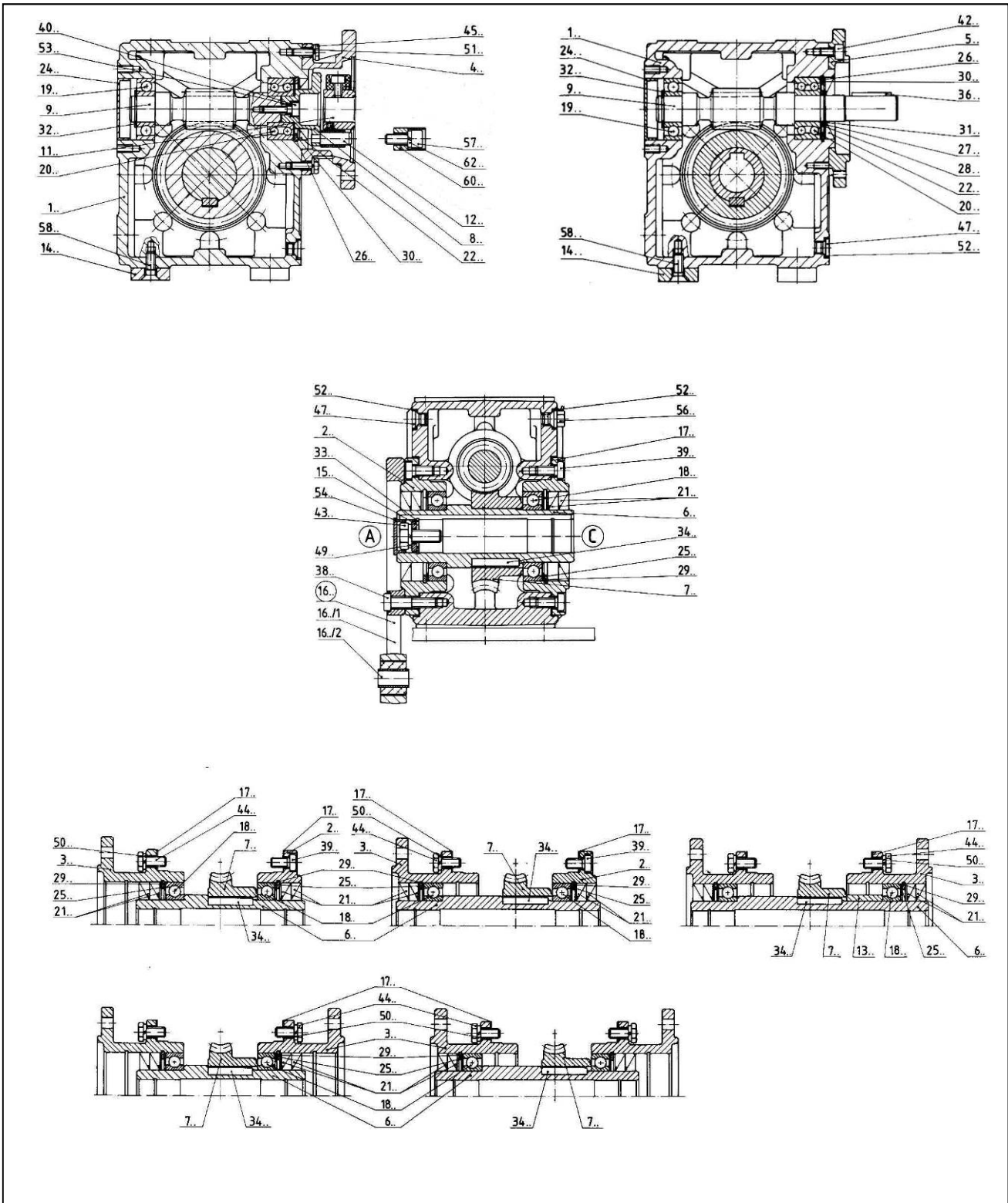

3.8 Basic construction helical worm gearbox SS130 – SS150

version WG,WF,WL,WD

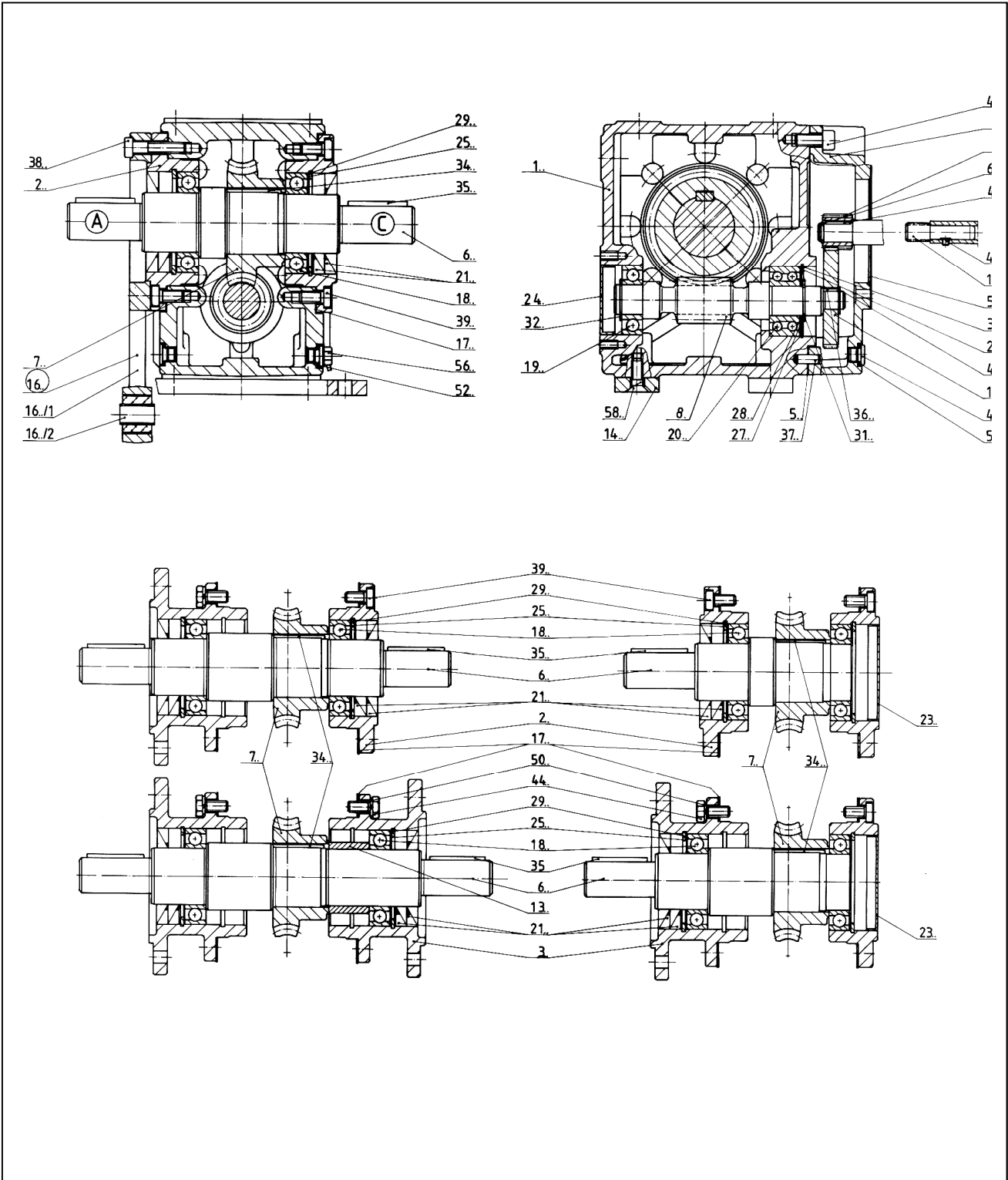

3.9 Basic construction helical worm gearbox SS130 – SS150

version HG, HF, HL, HD

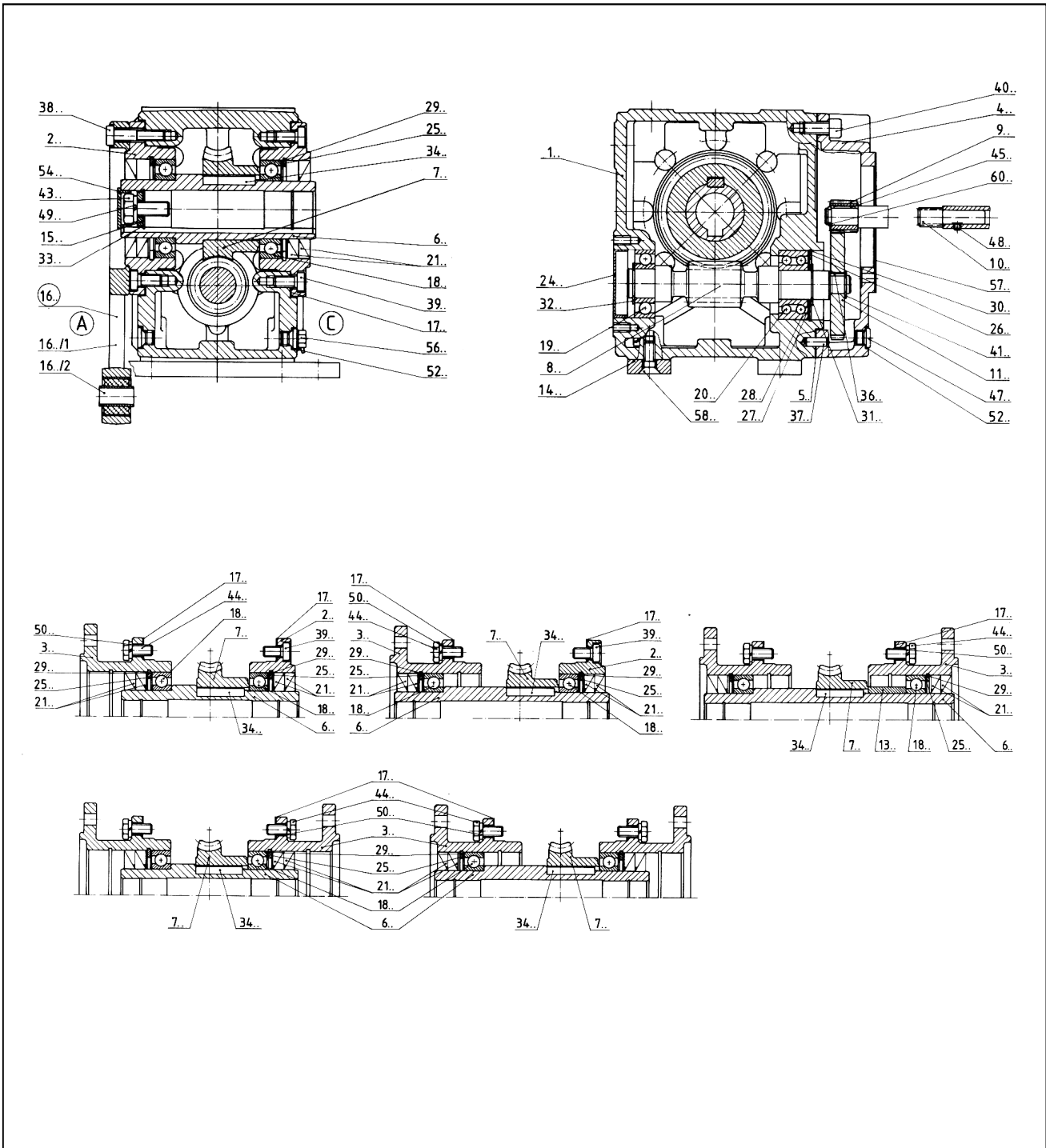

3.10 Basic construction helical worm gearbox SS160 - SS170

version WG,WF,WL,WD

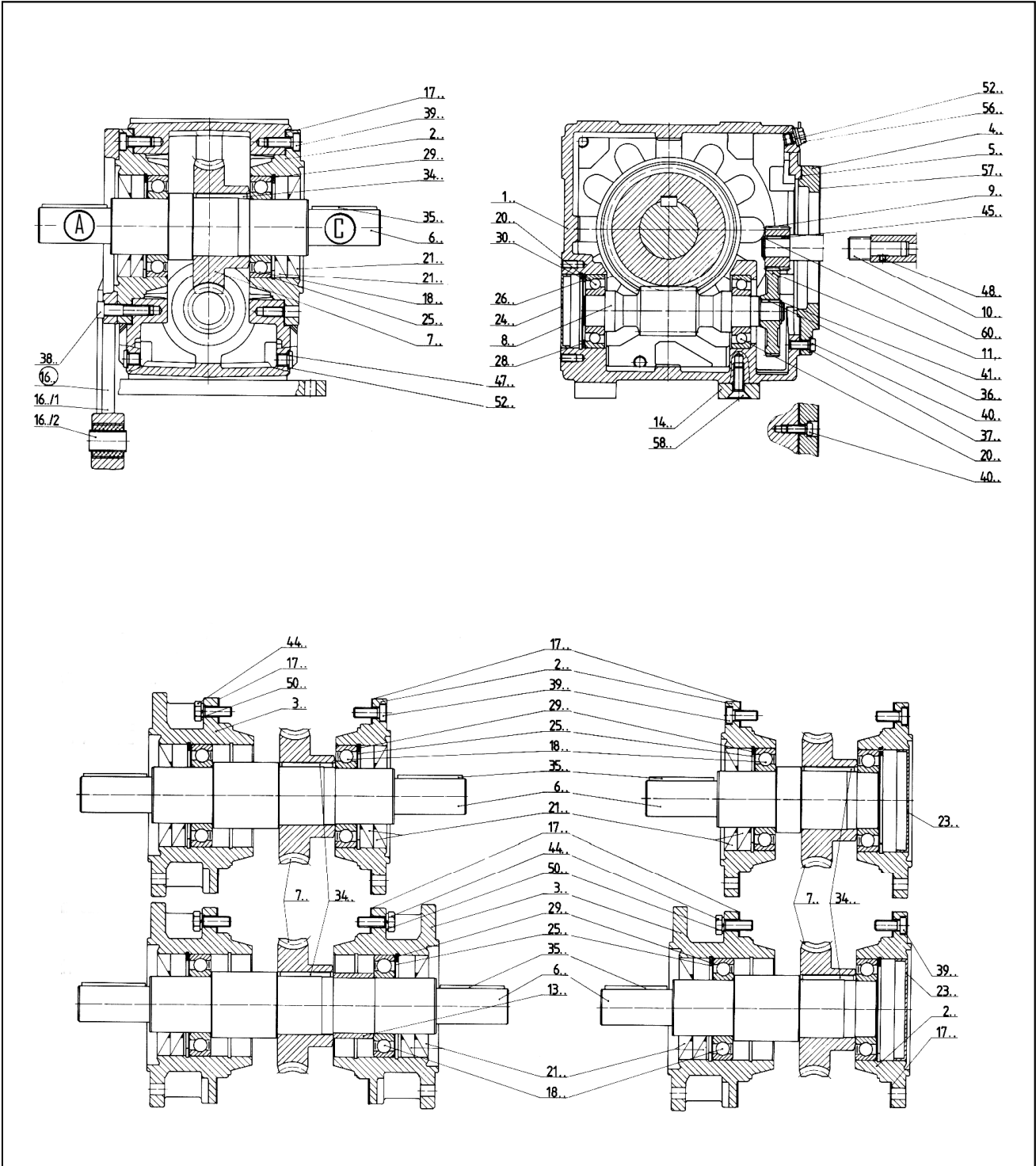

3.11 Basic construction helical worm gearbox SS160 - SS170

version HG,HF,HL,HD

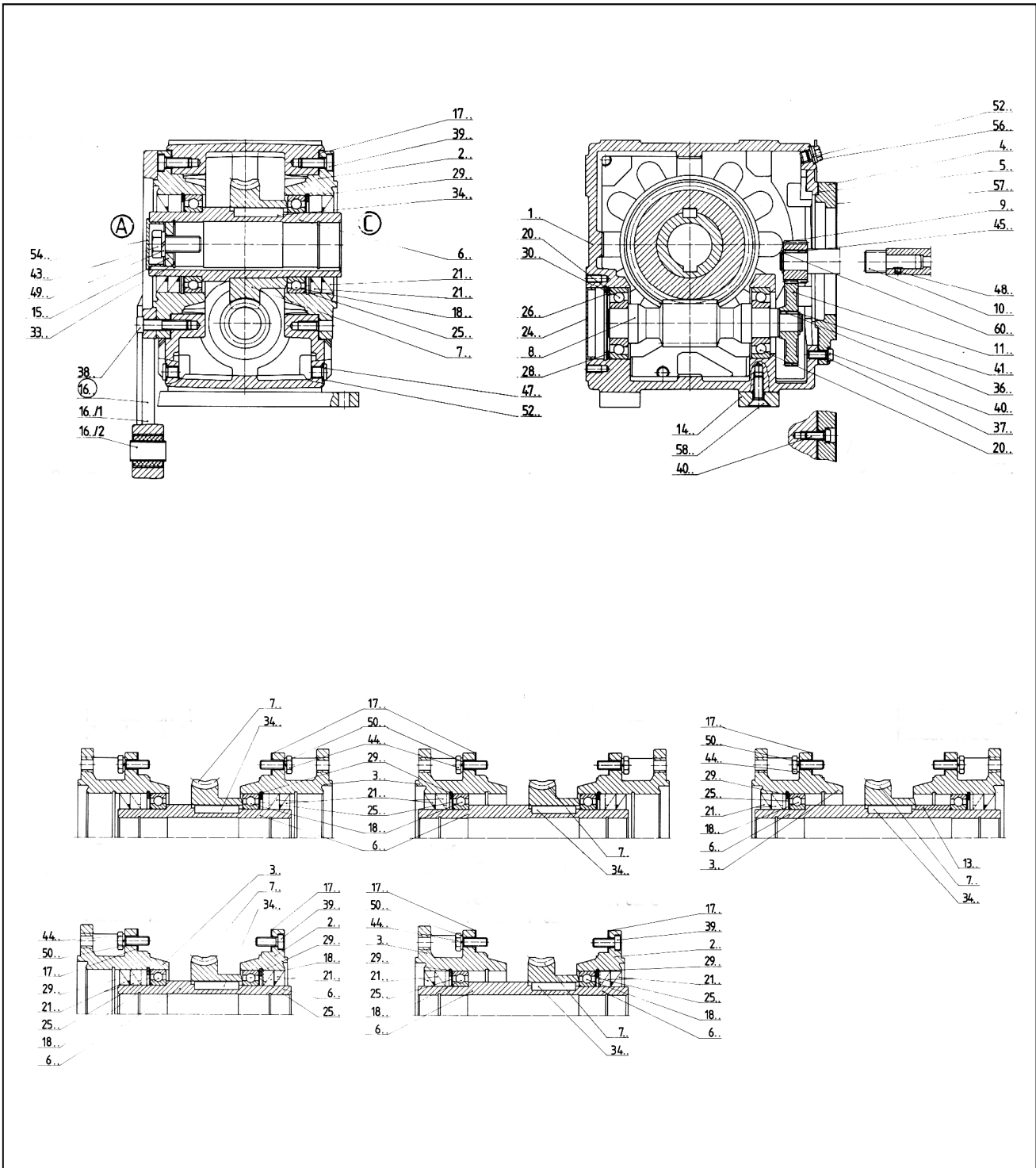

3.12 Basic construction worm gearbox SM011, SM(N)021– SM(N)031

version WG,WGU,WF,WFU

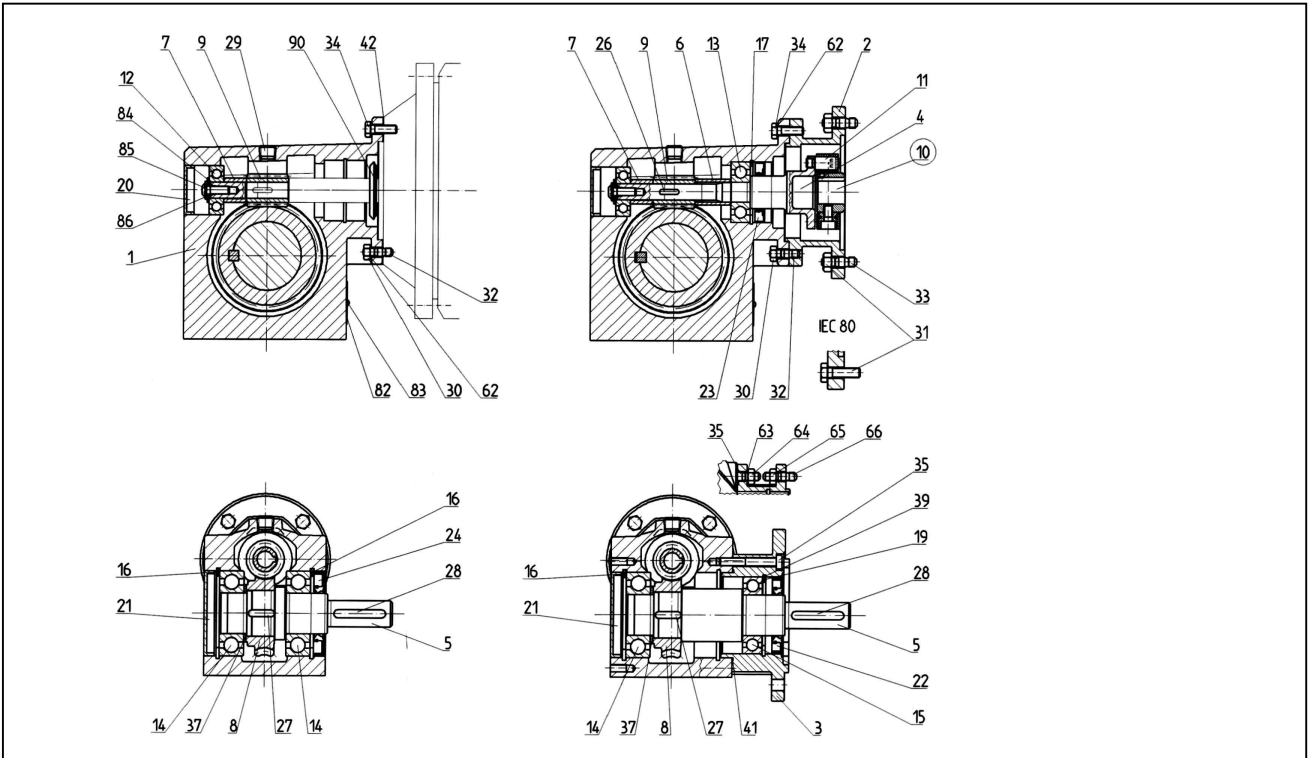

version HG,HGU,HF,HFU

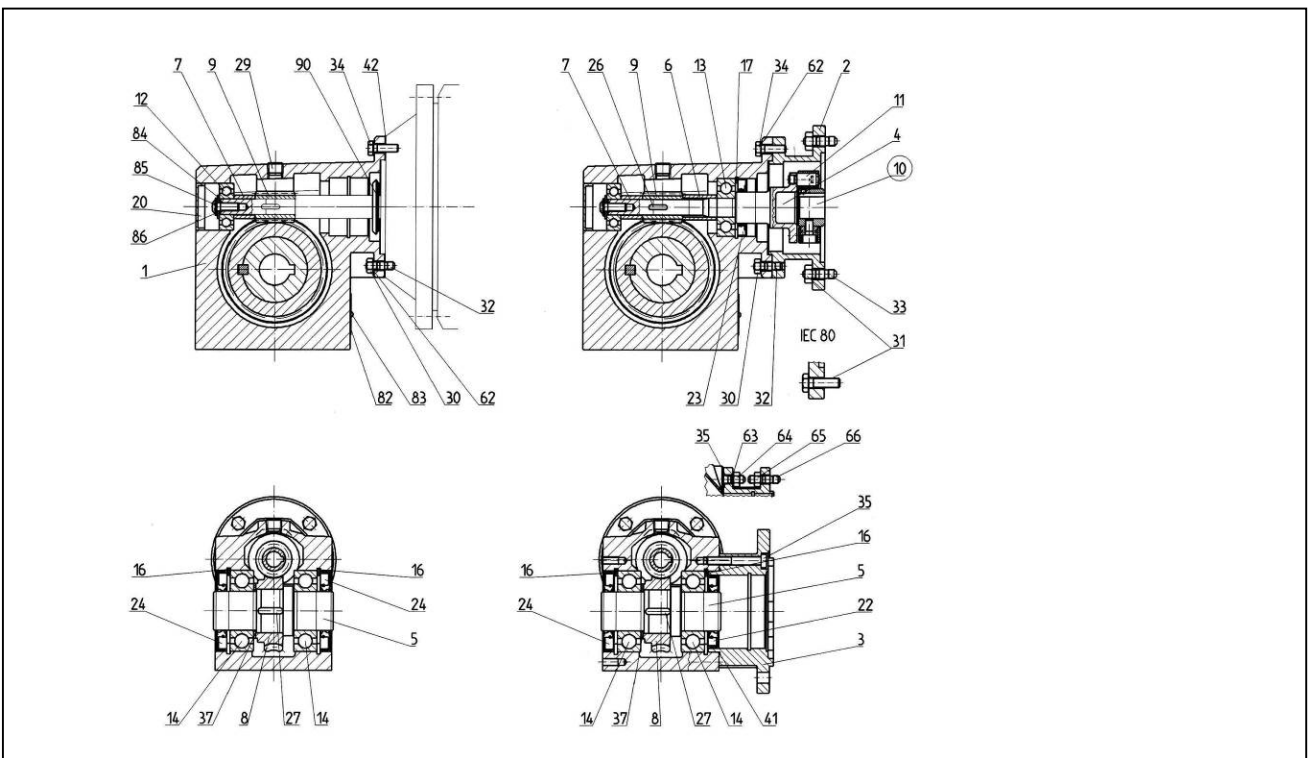

3.13 Basic construction worm gearbox SM041

version WG,WGU,WF,WFU

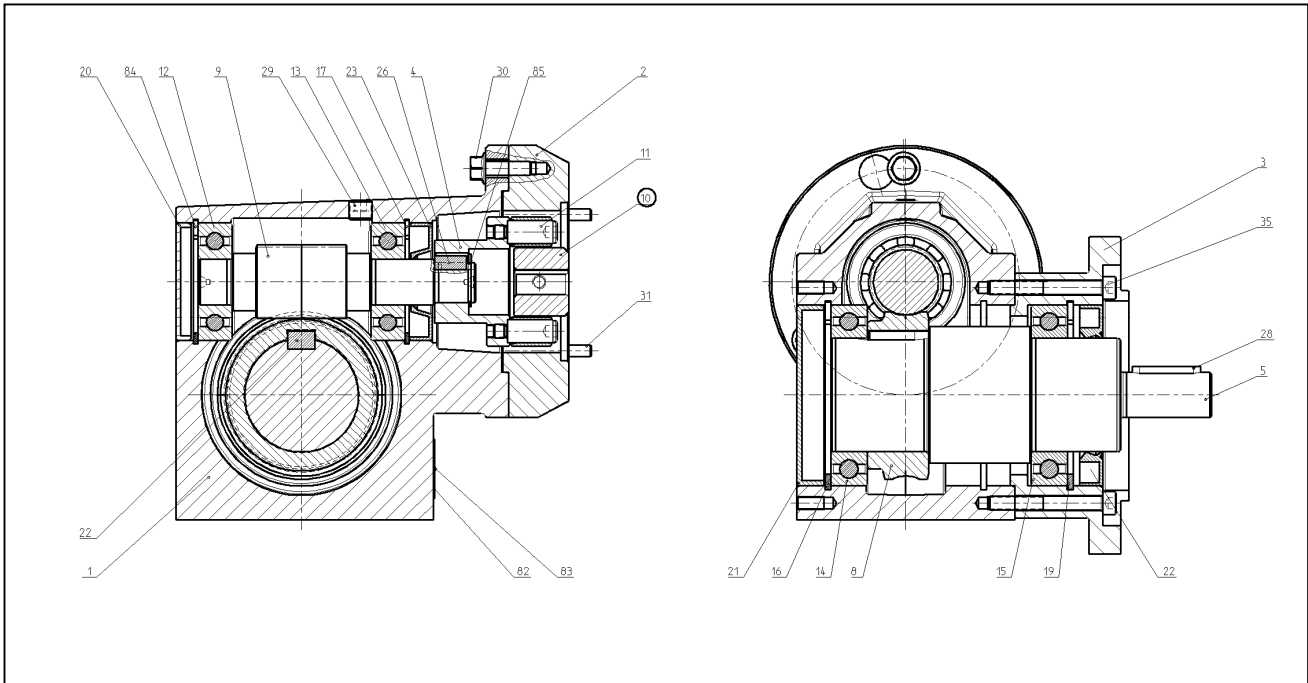

version HG,HGU,HF,HFU

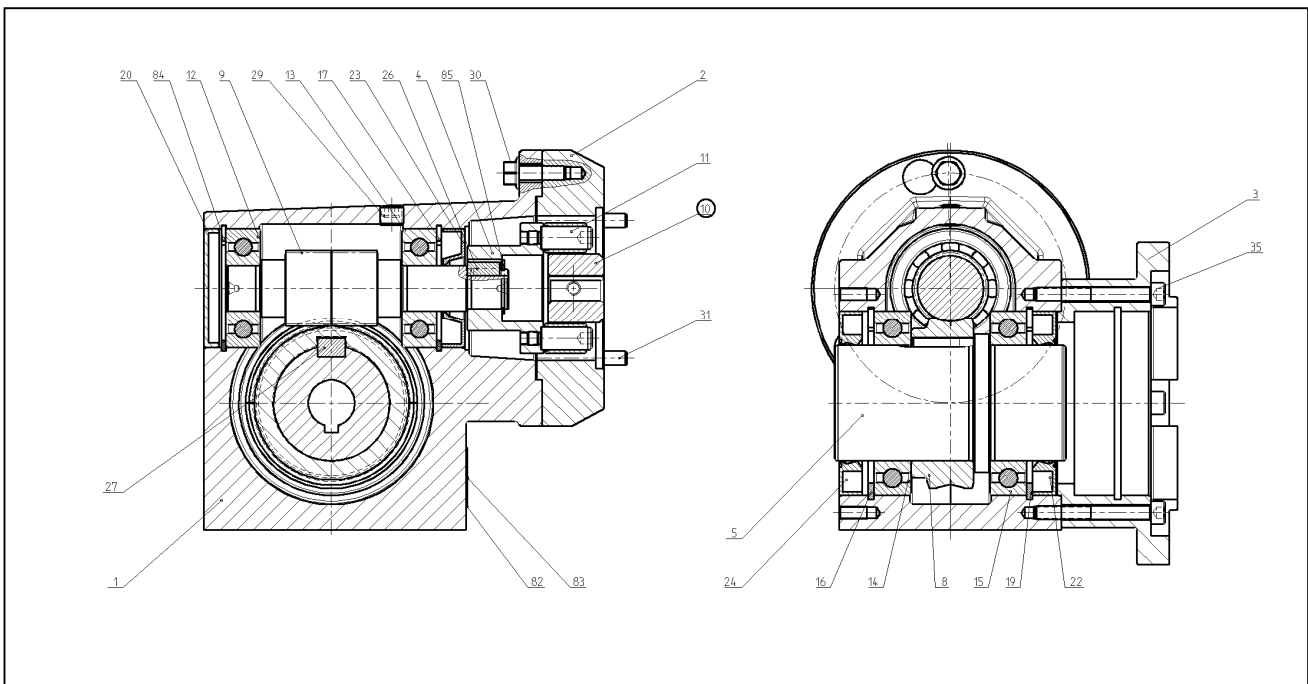

3.14 Basic construction worm gearbox SM(N)051 – SM061

version WG,WGU,WF,WFU

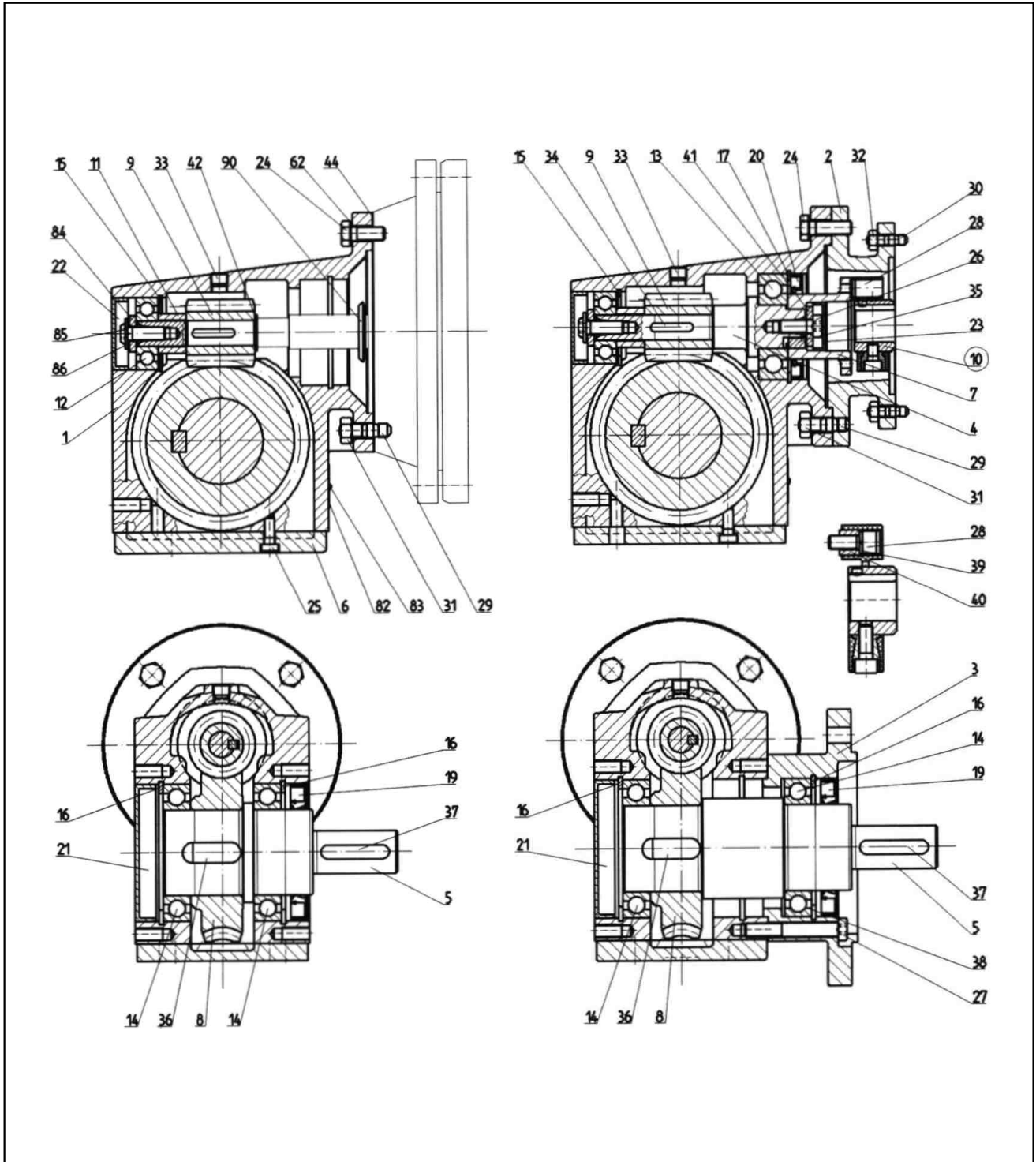

3.15 Basic construction worm gearbox SM(N)051 – SM061

version HG,HGU,HF,HFU

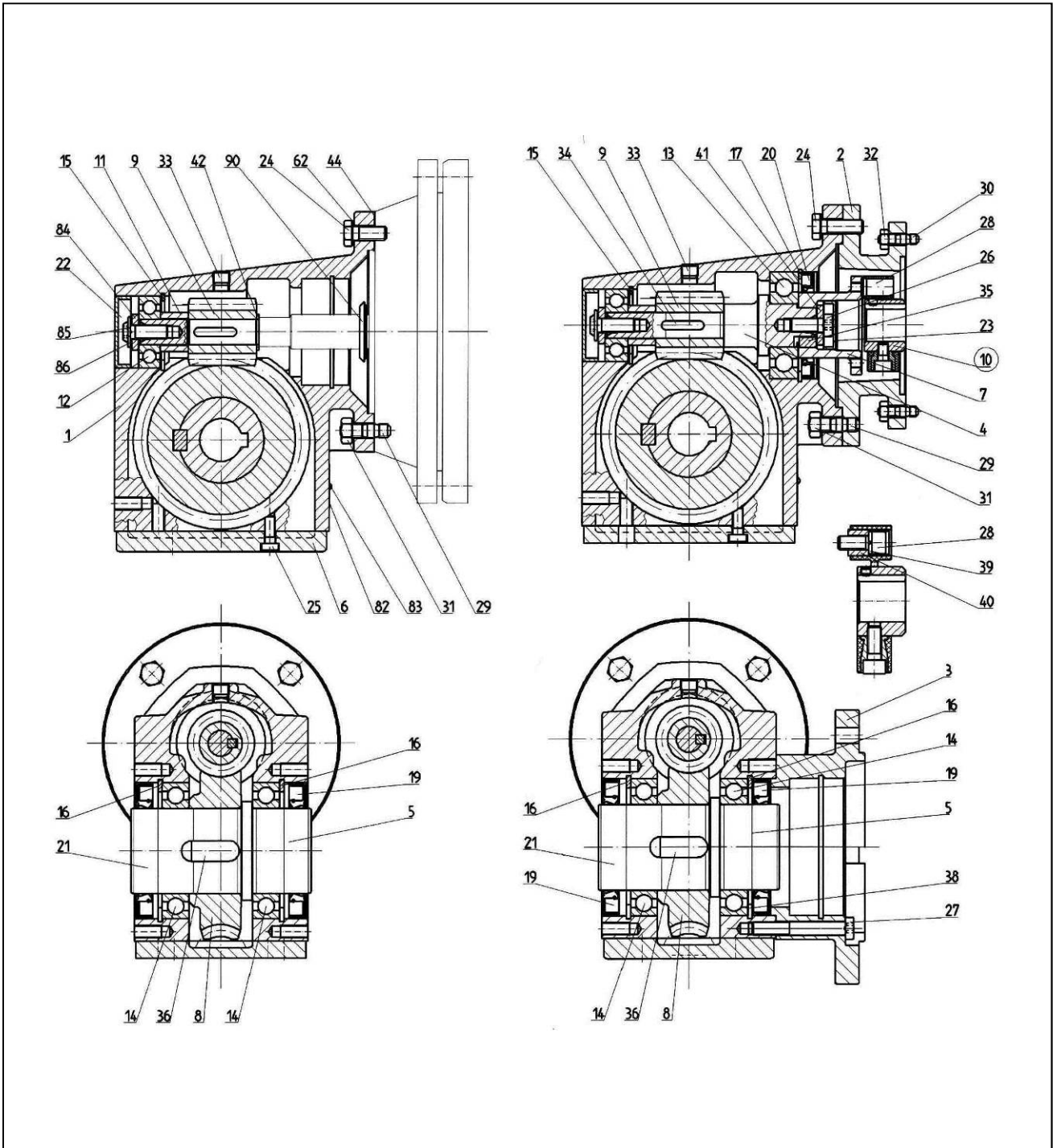

3.16 Basic construction worm gearbox SSM 121 – SSM131

version WG,WGU,WF,WFU - HG,HGU,HF,HFU

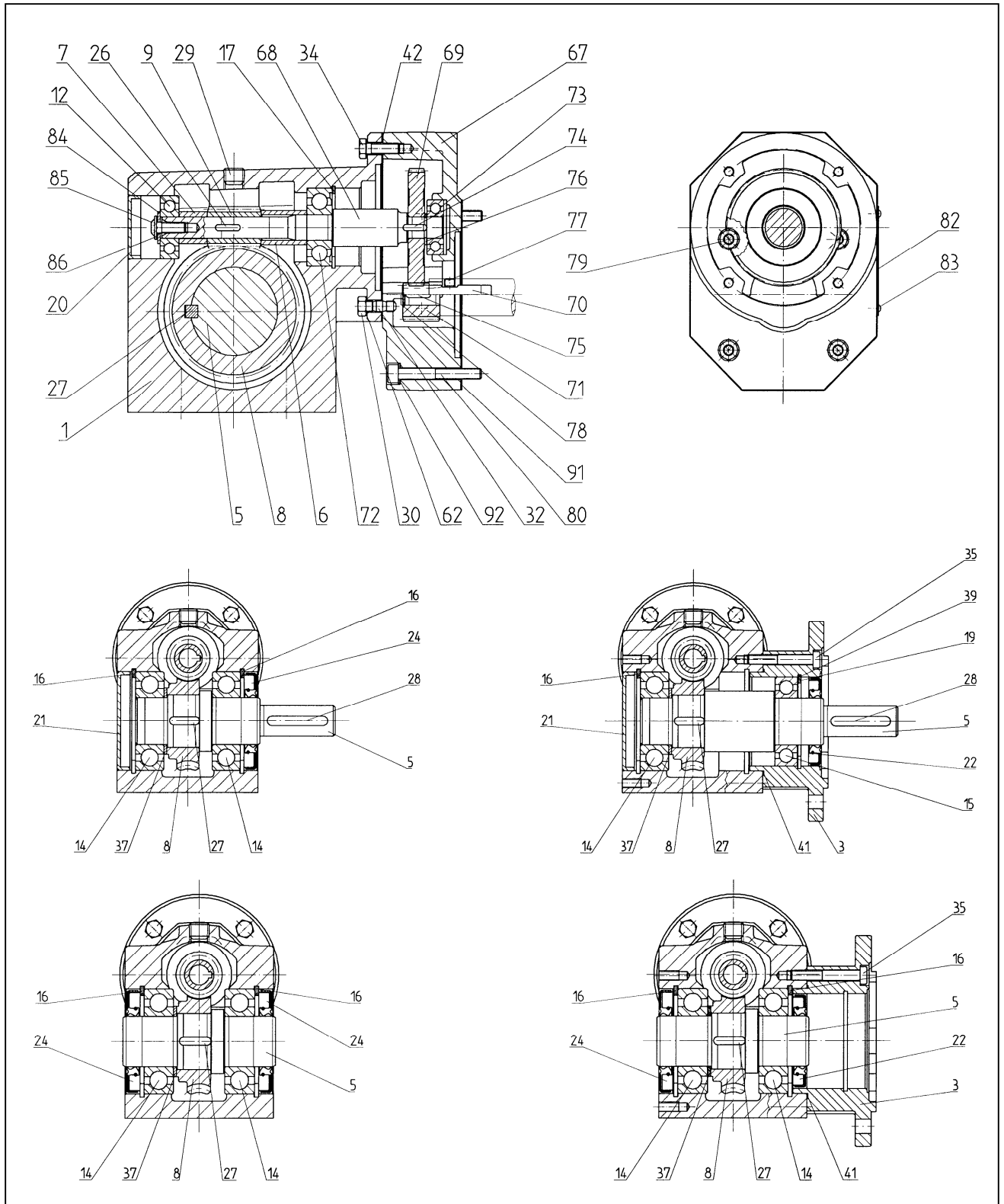

3.17 Basic construction worm gearbox SSM151 – SSM161

version WG,WGU,WF,WFU - HG,HGU,HF,HFU

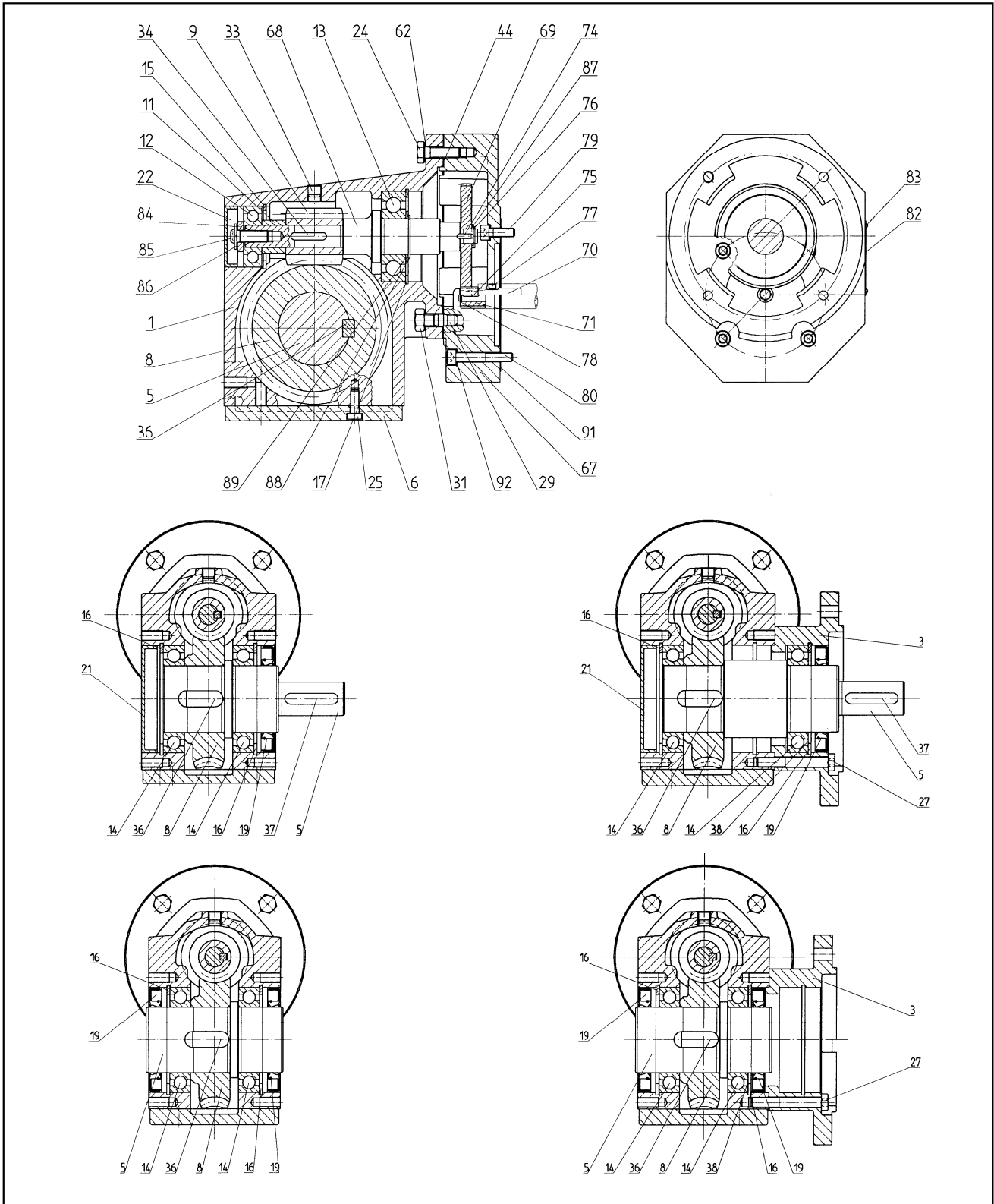

3.18 basic construction slip clutch

worm gearbox S, SS

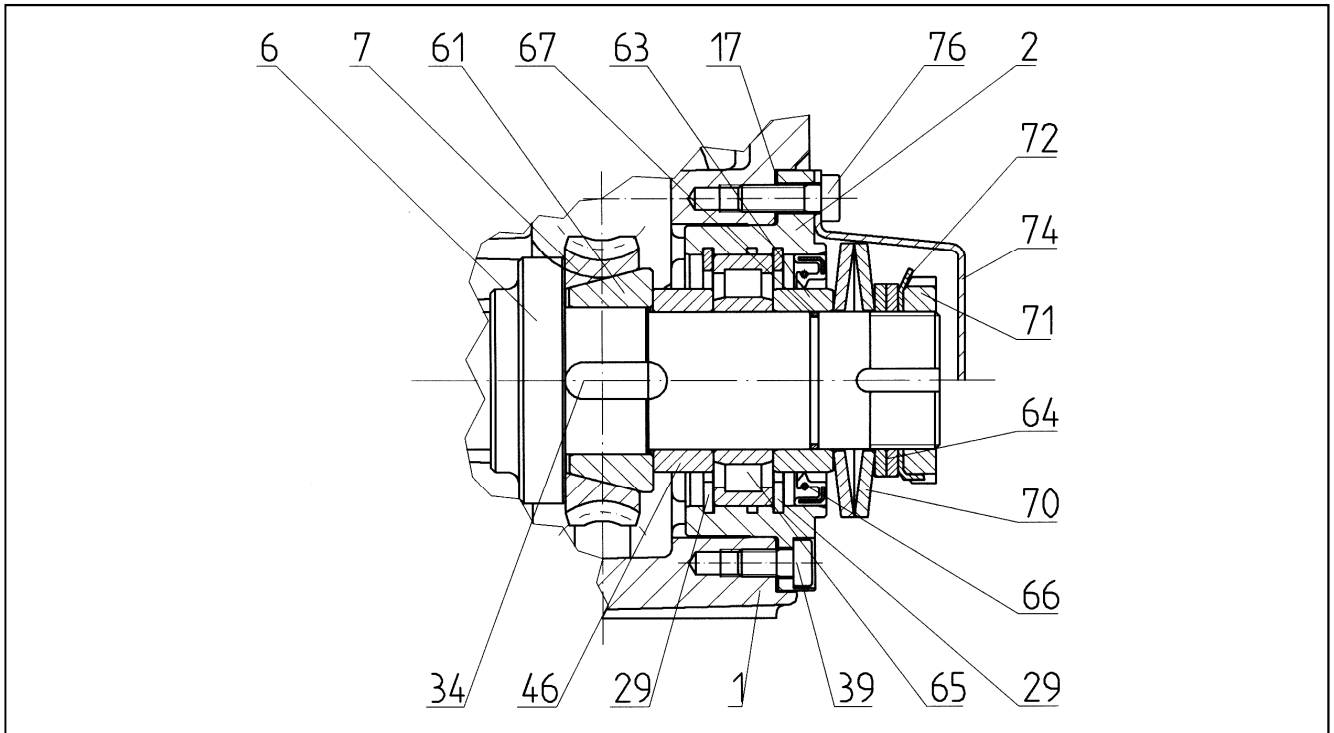

Worm gearbox SM, SSM

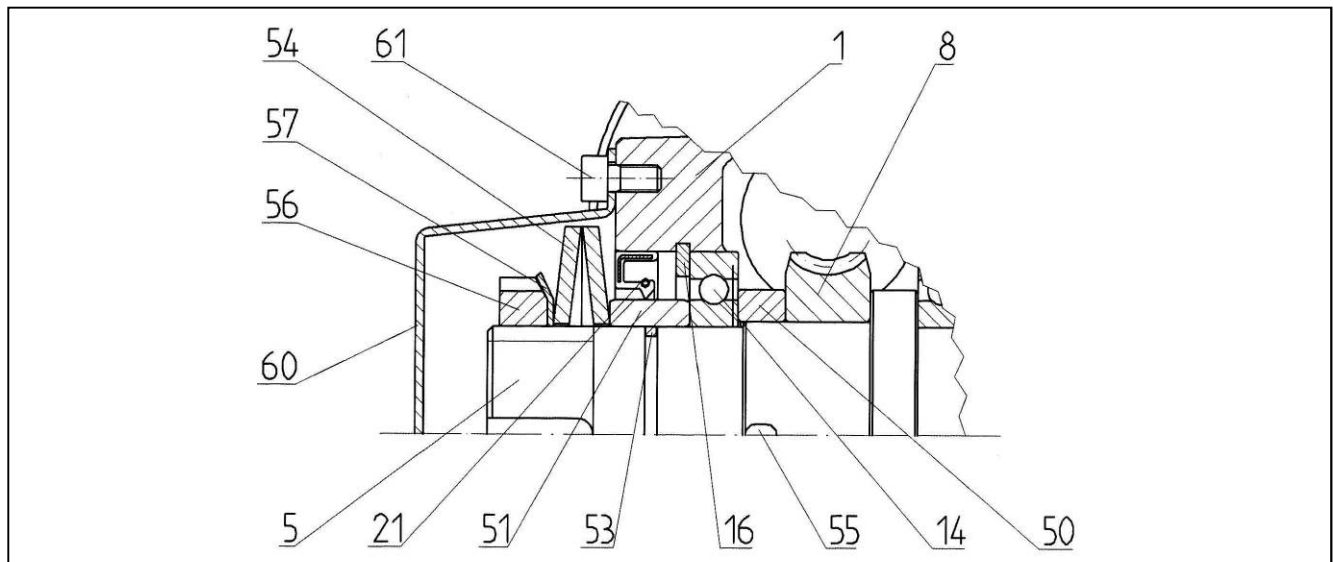

3.19 Basic construction IEC – Adapter

size 56 – 71

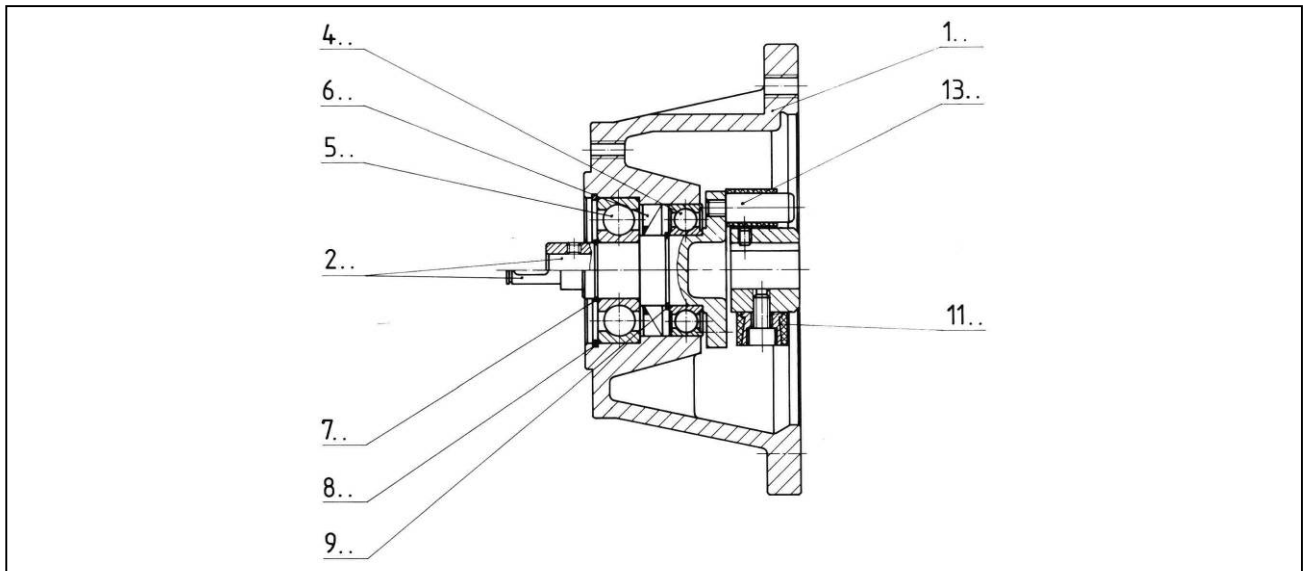

size 80 – 180

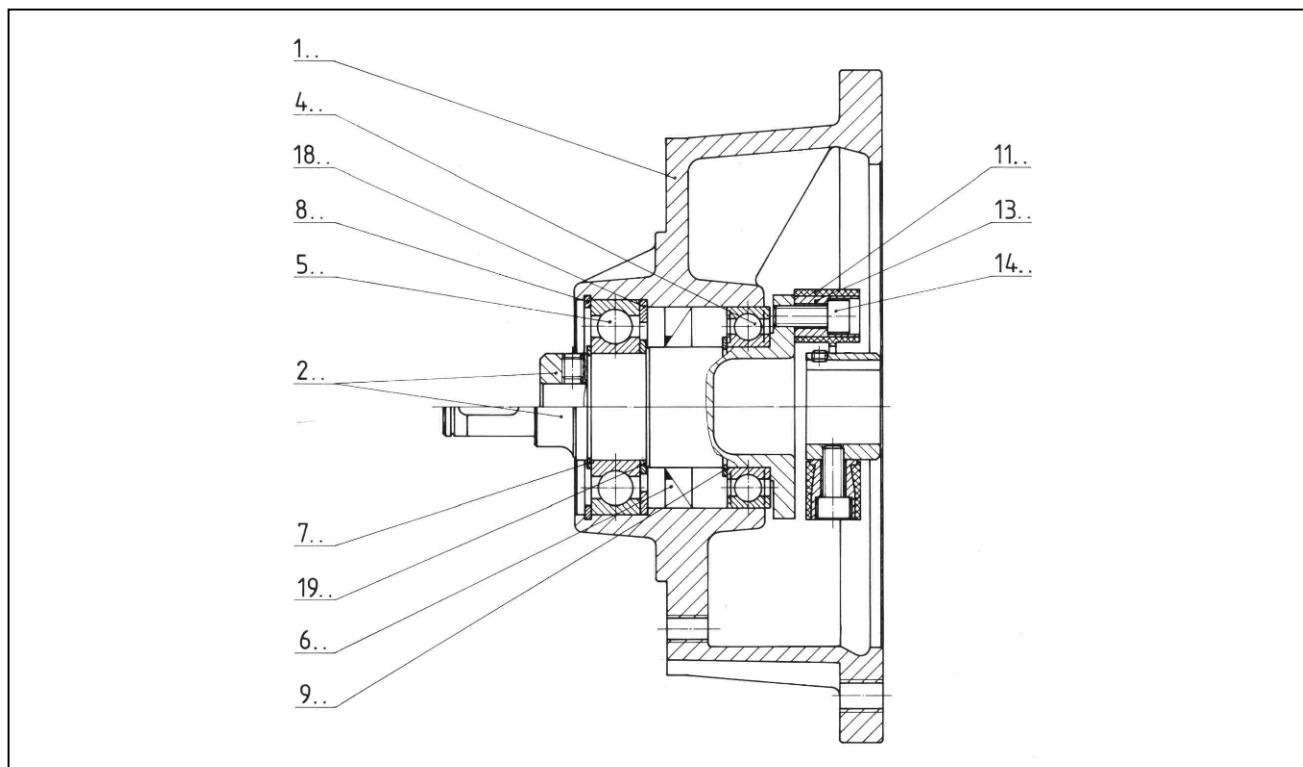

3.20 Basic construction free input shaft

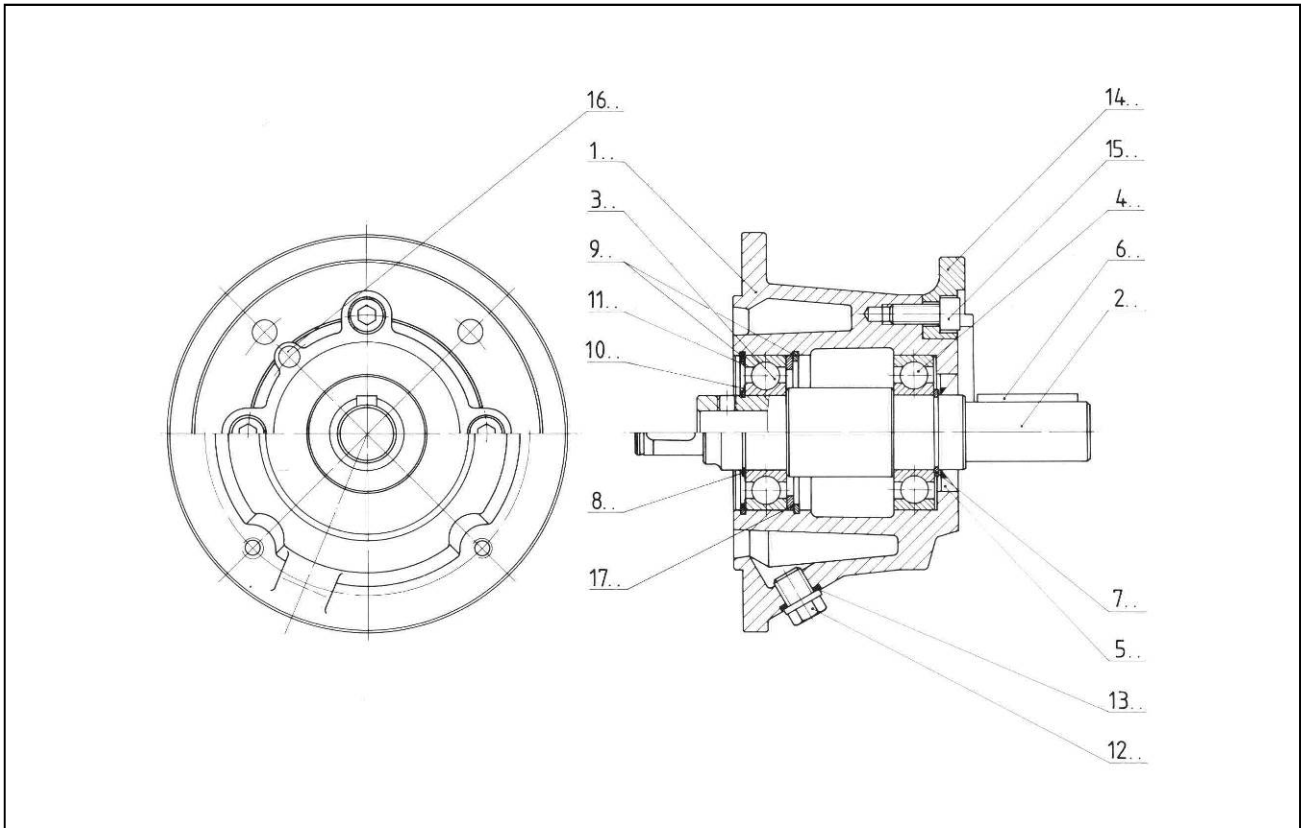

4 Mechanical Installation

4.1 required tools

- Wrench set
- torque wrench (for shrink discs)
- mounting press
- equalisation elements if needed (discs, distance rings)
- fixing material for input- output elements
- lubricant
- screw protection (for cover on input side with centring ring). z. B. Loctite
all screws which had to be disengaged have to be secured again with screw protection (liquid or mechanical)

Tolerances at installation

Shaft end	flange
Tolerance on diameter according to DIN 748 ISO k6 at solid shaft < 50 mm ISO m6 at solid shaft > 50 mm ISO H7 at hollow shaft Centre bore according to DIN 332, Form D	Tolerance on centring according to DIN 42948 ISO j6 at $b1 \leq 230$ mm

4.2 Before you start

The drive may only be installed if:

Information on nameplate of drive corresponds to the approved on site explosion application range (equipment group, category, zone, temperature class or maximum surface temperature)

The drive is not damaged (no damage resulting from shipping or storage)

The following requirements have been properly met:

There are no potentially explosive atmospheres, oils, acids, gases, vapours, radiation etc. during installation.

For standard drives: ambient temperature $-5^{\circ}\text{C} - +40^{\circ}\text{C}$

For worm gearboxes: there is no extern mass moment of inertia which might drive back gearbox on load
 [at η' (back driving) = $2 - 1/\eta < 0,5$ retained by friction].

4.3 Preparation

Output shafts and flanges must be completely free of anti-corrosion agents, contamination or other impurities (use a commercially available solvent) Do not let solvent get in contact with the sealing lips of the oil seals – danger of damage of the material.

4.4 Installation of gearbox

The gearbox or geared motor may be mounted or installed in the specified position (SM(N)/SSM gearbox are position independent) only on a level, vibration free or torsionally rigid support structure. Do not tighten housing legs and mounting flanges against each other.

For mounting of geared motors use screws in quality 8.8 only!



**Oil control and drain screws must be easily accessible!
When mounting customer's parts protection class has to be maintained!**

Before starting check specified lubricate quantity! (Chapter "Lubricant" – information on nameplate)

We deliver gears with necessary lubricant quantity. Slight deviation is possible and allowed within tolerance. Check oillevel before starting (-> chapter "Inspection / Maintenance").

Alter design only after prior agreement with Rehfuss.

Use plastic inserts when there is danger of electrochemical corrosion between gear and machine (connection of mixed materials as cast/steel). Use plastic inserts 2-3 mm thick. Use plastic washers for screws! Plastic used must have bleeder resistor of $< 10^9 \Omega$. Ground gear housings on principle. For geared motors use additionally grounding screws on motor. Ensure adequate supply of cooling air and that heated air from other units is not drawn in. The cooling air may not exceed a temperature of 40°C. No metal parts must be mounted isolated.

Installation in damp areas or in the open

Drives might be supplied in corrosion-resistant versions for use in damp areas or in the open. Any damages to the paintwork (e.g. on the breather valve) must be repaired.

Ventilation of gearboxes

No ventilation necessary for below gearboxes:

SM(N)/SSM –gearboxes

All remaining gears are supplied by Rehfuss with adequate and activated breather valves.

Exception:

Gearboxes for extended storage and when mounted on sloping level are supplied with protection cap on breather bore.

Before starting user has to change supplied breather valve against sealing plug in the highest position.

For geared motors for extended storage and for mounting in sloping level supplied breather valve finds in Terminal Box of motor.

Gearboxes in closed design are supplied without breather valve.

Breather valves are activated ex works normally.

Painting the gear unit

If the drive will be over painted or partially repainted, ensure that the breather valve and oil seals are carefully covered with tape. Remove tape strips after the paint work is finished.

Seals must be compatible!

4.5 Gears with solid shaft

Mounting of Input and output components

The figure below shows an example of a mounting device for mounting clutches or hubs onto shaft ends of gear units or motors. Where required, the thrust bearing on the mounting device can be removed.

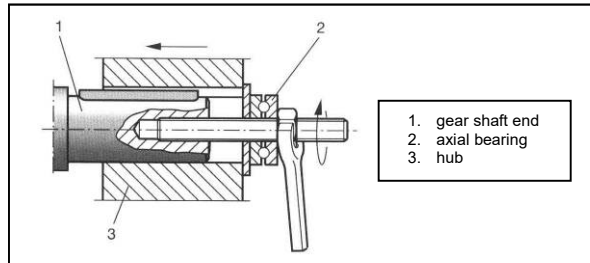

The following figure shows the correct mounting arrangement B of a gear or sprocket to avoid excessive overhangs loaded.

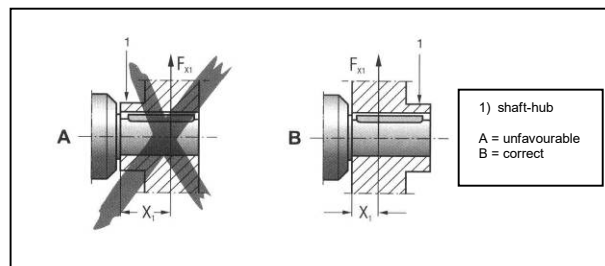

Only use a mounting device for installing input and output-elements. Use the centre bore and the thread on the shaft end for positioning purposes.

Never mount belt pulleys, clutches, pinions etc. onto the shaft end by hitting them with a hammer (damage to bearings, housing and the shaft!).

Observe correct tension of the belt for belt pulleys (in accordance with manufacturer’s specifications).

Power transmission elements should be balanced after installation and must not rise to excessive radial or axial forces (see the “Gearmotors” catalogue for approved values).



Assembly is easier if you first apply lubricant to the output element or heat it up briefly (to 80-100°C).

Mounting of couplings

The following items have to be balanced according to the coupling manufacturer’s specifications when mounting couplings:

- a) Maximum and minimum clearance
- b) Axial offset
- c) angular offset



Input and output elements such as belt pulleys, clutches etc. must be equipped with a touch guard!

4.6 Mounting torque arm

do not stain when mounting!
Support jack on both sides.

4.7 Mounting/Dismantling on Shaft gearboxes with hollow shaft



Please refer for design of user's shaft Construction information in catalogue!

Mounting is easier when using a mounting device..

For axial safety of shaft Option „Fixing elements“ may be used.

To avoid corrosion we recommend to turn free user's shaft between the 2 bearing surfaces!

Dismantling only with appropriate device.



Only mount / dismantle drives with appropriate device. Hitting on drives or shafts might damage bearings, housings or shafts).

4.8 Mounting/Dismantling of Shaft gears with shrink discs and cowl



Do not tighten clamping screw when shaft is not fixed! Hollow shaft might deform.
Clamping area of shrink disc must be free from any grease!

Assembly

1. loosen clamping screws slightly (do not remove entirely!).
2. carefully lubricate hollow shaft boring and Input shaft.
3. join degreased hollow shaft/Input shaft.

Assemble input shaft, note parallel position of outer rings of shrink discs. For housing with shaft collar fix shrink disc with bearing of 1 to 2 mm to housing of gearbox. Tighten clamping screws in a row (not crossing) with torque wrench till crews do not move any more. Pick-up of crews are noted on shrink discs.



After assembly there must be a remaining clearance $s > 1$ mm.
Outer flanges of hollow shaft in reach of shrink disc should be greased for corrosion protection.

Dismantling of shrink disc

1. Loosen clamping screws steadily and in a line. Each screw must only be loosened approximately. A quarter of a turn in the beginning to avoid unleveling of outer race. Do not totally remove screws!
2. Remove shaft respectively remove hub from shaft (remove corrosion that might be on shaft in front of hub first)
3. Remove shrink disc from hub..



Danger When shrink disc is dismantled inappropriately you might be injured!

Cleaning and lubrication of shrink disc

Dismantled shrink discs do not have to be disassembled and lubricated when used again. If shrink disc is dirty it has to be cleaned and lubricated again.

Use one of the below lubricants (Spray or Paste).

Lubricant (Mo S2) e.g.: Molykote 321 (), Molykote Spray (Powder-Spray), Molykote G Rapid, Aemasol MO 19P, AemasolDI0-sétral 57 N .

Lubricate clamping screws with general purpose lubricant Molykote BR 2 or similar.

4.9 Mounting of IEC-Adapter

1. Slide the coupling (1) up the motor shaft (2) until the hub rests against the shaft collar (a) and flange facing (a) lie on a single plane and that the highly chamfered side (b) faces the motor flange (3). This guarantees the correct distance between the coupling and the coupling shaft (4).
2. Tighten the radial locking screw (5) in the hub.
3. Implace the motor on IEC-Adapter (6). In doing so, insure that the socket pins (7) have been correctly inserted into the bore holes (c) of the coupling ring.
4. Screw the motor an the IEC-Adapter together.

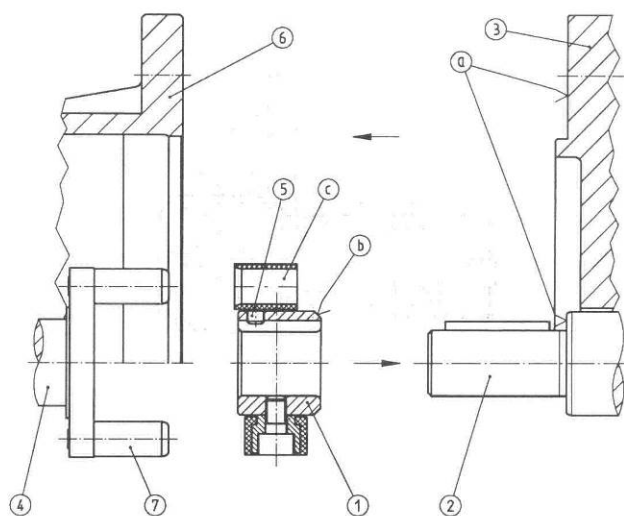

Note: We recommend to use anti-corrosion agents on motor shaft before mounting coupling hub.

4.10 Mounting of IEC-Adapter with adapter flange

1. Slide the coupling (1) up the motor shaft (2) up to distance X between hub and shaft collar. It is essential that shaft collar (a) and flange (a) lie in line and the highly chamfered side (b) faces to motor flange (3). This guarantees the correct distance between the coupling and the coupling shaft (4).
2. Tighten the radial locking screw (5) in the hub.
3. Implace the motor with adapter flange (8) on IEC-Adapter (6).. Ensure that socket pins (7) have been correctly inserted into the bore holes (c) of the coupling ring.
4. Screw the motor on IEC-Adapter.

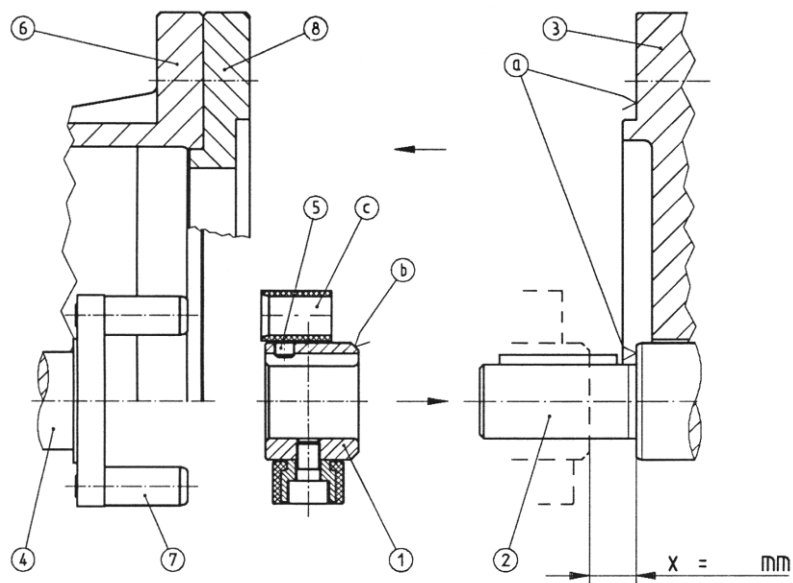

Note: We recommend to use anti-corrosion agents on motor shaft before mounting coupling hub.

4.11 Mounting of IEC-Adapter by SM041

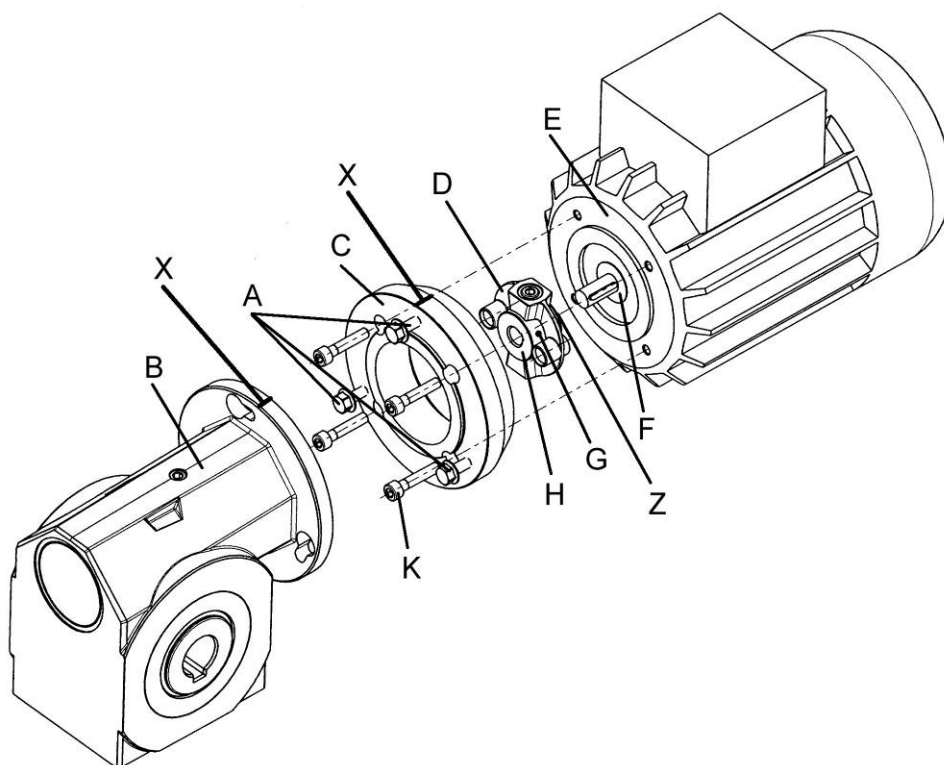

Gearbox (B) is supplied complete with Motor adaptor (C) and fixing screws (K) for Motor (E).

1. Loosen 3 locking screws (A) on gearbox side (do not take out!) Note marking "X". Remove Motor adaptor (C) from gearbox by turning (Bayonet). Then take off coupling (D) from drive pins.
2. Slide on coupling with face (Z) of the Coupling hub (H) onto the motor shaft towards motor flange side (E) until coupling hub (H) mounts to shaft collar (F). It is essential that shaft collar and flange face of motor are in line. Tighten radial locking screw (G) of coupling hub.
3. Put on motor adaptor (C) on motor flange and align according to required terminal box position. Orientate according to marking "X" on adaptor. Screw adaptor on motor flange.
4. Put motor with adaptor on gearbox and position by turning (bayonet). Markings on adaptor and gearbox have to be in line. Then tighten the 3 locking screws (A).

Allowed loads

Below load dates must not be exceeded by fixing a motor.

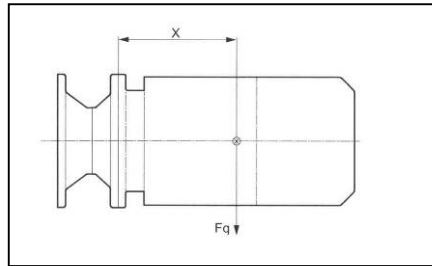

IEC Adapter size	X (mm)	Fq (N)
56	72	350
63/71	75	530
80/90	112	420
100/112	142	2000
132	184	4700
160/180	250	4600



Maximum allowed weight of attached motor F_{qmax} has to be reduced linearly when distance of centre of gravity x is increased. When distance of centre of gravity x is reduced no increase of maximum allowed weight F_{qmax} is allowed.

4.12 Mounting on free input shaft

For mounting of input drive element see chapter „Mounting of Input and output shafts.“

Variation with centring ring

Mounting of applications an input cover with centring ring.

1. To fix application provide screws in adequate lengths.
2. Clean joining faces and centring ring.
3. Put application on centring ring and tighten clamping screws with protection element and pick-up TA.

5 Installation



Check appropriate oil level before starting. Oil control and drain screws as well as breather breather screws and -valves must be easily accessible.

5.1 Control lubricant with Oil level screw

The 4-step gearboxes of series SR need a higher oil level which is necessary for sufficient lubrication,. Therefore added oillevel screws nut no be used. In this case necessarily contact REHFUSS!



1. Switch geared motor dead, make sure it cannot be started accidentally!
2. remove Oillevel screw..
3. If required correct filling level, fix oillevel screw again (insert sealing ring and seal with sealing liquid).

5.2 Control lubricant on gearboxes without oil level screw



Below series of gearboxes have no oil level screw:
SM(N)/SSM
Oillevel is controlled with oil filling screw on these gearboxes.



1. Switch geared motor dead, make sure it cannot be started accidentally!
2. Put up gearboxes in mounting positions B6 or B7 i.e. Oil filling screw is used as oillevel screw.
3. Loosen oil filling screw..
4. Oil level has to be up to thread..
5. Seal oillevel screw of gearbox after controlling lubricant with liquid sealant..

5.3 Starting of worm gearbox

warmup time

Worm gearboxes need a warmup time of at least 24 hours, to reach maximum performance. Is gearbox operated in both turning directions, a warmup time for each of the directions is necessary. Average reduction of performance during warmup time is approximately 5%.

5.4 Starting of helical and shaft mounted gearboxes

There are no special instructions for installation of helical or shaft mounted gearboxes if gearboxes are mounted according to chapter "mechanical Installation".

5.5 Starting gearboxes / geared motors

Solo gearboxes

Ensure that Values stated on nameplate of gearboxes with IEC-Adapter or free input shaft are not exceeded. Prevent overload of gearbox.

Mainsloaded motors

Make sure that information stated on nameplates of gearbox and motor correspond to ambient conditions in site.

Geared motors used with frequency inverters

Make sure geared motor is certified for inverter use. Parameter of inverter have to prevent overload of gearbox. For allowed power rate of gearbox see nameplate.

6 Inspection and Maintenance

Plastic surfaces must only be wiped damply (electrostatic charging).
 Make sure that there is no dust accumulation of more than 5 mm (clean regularly).

6.1 Inspection and maintenance intervals

Interval	What is to do?
every 3000 operating hours, at least every 6 months	Control oil and lubricant level View seals on leaking, replace if required Check rubber buffer on gearboxes with torque arm
According to operation conditions (see below table), at least every 3 year according to oil temperature	Replace mineral oil Replace grease of rolling bearing if required Replace shaft seals
According to operation conditions (see below table), at least every 5 year according to oil temperature	Replace synthetic oil Replace grease of rolling bearing if required Replace shaft seals
variable (depending on external influences)	Repair or replace paint / corrosion protection

Gearboxes SM(N) / SSM have lifetime lubricant are so need no maintenance

6.2 Intervals for changing lubricants

Intervals for replacement on standard-gearboxes with mineral oil filling under regular conditions

Permanent Lubricant temperature- in °C	Replace lubricant after operating hours
Up to 70	10000
71 - 80	7500
81 - 90	5000
91 - 100	2500
over 101	1250

Intervals for replacement on standard-gearboxes with synthetic oil filling under regular conditions

Permanent Lubricant temperature- in °C	Replace lubricant after operating hours
Up to 70	20000
71 - 80	15000
81 - 90	10000
91 - 100	5000
over 101	2500

On special design under heavy / aggressive ambient conditions change lubricant more often!



Reh fuss recommends when replacing lubricant on rolling bearings with grease filling replace grease as well. Below quantities are needed:

For fast running bearings (Motor and gearbox –input side) fill hollow spaces between rolling elements up to 1/3

For slowly running bearings (in gearbox and gearbox output side): Fill 2/3 of hollow spaces with grease

6.3 Intervals for changing rolling bearings

Rolling bearings are oiled or greased. Replace bearings before they fail. Indicators are running noise and temperature..
According to performance below average values have to be considered

performance fb	Replace after operating hours
1	2500
1,2	4500
1,4	7000
1,6	10500
1,8	15000
2,0	20000

6.4 Inspection / Maintenance gearbox

As standard we use synthetic lubricant. Position of Oillevel and drain screws and breather valve see drawings of the variations. All loosened screws have to be tightened again with screw protection! Do not mix synthetic oils with each other or with mineral oils.

Check Lubricant level



1. Switch gearbox dead, Protect against unintended start! Wait till gearbox has cooled down – danger of burning!
2. When design has be amended please contact REHFUSS!
3. Check lubricant according to chapter start up „Check oil level on gearboxes with/without oil level screw“

Replace lubricant



Replace lubricant only on gearboxes that are worm from operation.

1. Switch gearbox dead, Protect against unintended start! Wait till gearbox has cooled down – danger of burning!
Note: Gearbox has to be warm however as total draining is more difficult when oil is too cold.
2. For gearboxes with drain screw/Oillevel screw:
3. Put vessel under drain screw.
4. remove oillevel screw, breather screw /-valve and drain screw
5. drain oil totally
6. insert oillevel screw again.
7. Replace lubrication of same kind into breather bore (otherwise contact service) quantity according to variation (see chapter „lubricant capacity“) or to instruction on nameplate. Check on oillevel screw.
8. insert oillevel screw.
9. insert breather screw/valve.

Replace shaft seals



1. Switch gearbox dead, Protect against unintended start! Wait till gearbox has cooled down – danger of burning!
2. Ensure there is sufficient grease between dirt lip and sealing lip according to variation
3. When using double shaft seals fill space between 1/3 with grease.

6.5 Inspection / maintenance IEC-adapter

interval	What to do?
every 3000 operating hours, at least every 6 months	Check clearance View coupling View adapter for leaking
after 25000 - 30000 operating hours	Replace rolling bearing grease if required Replace coupling

6.6 Inspection / Maintenance free input shaft

interval	What to do?
every 3000 operating hours, at least every 6 months	Check running noise View for leaking
after 25000 - 30000 operating hours	Replace rolling bearing grease if required Replace shaft seals

7 Malfunctions

Service

Please provide the following information if you require assistance from our customer service:

Nameplate information (complete), Nature and extent of the problem, time and circumstances of problem, presumed cause

7.1 Malfunction on gearbox

Problem	Possible cause	Solution
unusual, continuous running noise	Noise reeling/grinding: damage on bearing	Check lubricant and quantity – (see „inspection and maintenance“), contact REHFUSS replace bearing.
	noise knocking: irregular toothing	Contact REHFUSS
Unusual, differential running noise	Alien element in lubricant	Check lubricant and quantity – (see „inspection and maintenance“), stop engine. Contact REHFUSS
Oil leaking On motor shaft seals On gear flange On output shaft seal	Bearing defective	Contact REHFUSS
Oil leaking on breather valve	Too much oil Drive used in incorrect mounting position Frequent cold started (oil frothing) and / or high oil level Breather valve dirty	contact REHFUSS
Output shaft not turning although motor is running or input shaft is turned	Connection shaft-hub in gear interrupted	Return to REHFUSS for repair.

Leaking oil/grease on shaft seal (low quantities) during warm up time (24 operating hours) are considered normal (see DIN 3761).

7.2 Malfunction on IEC-Adapter

Problem	Possible cause	Solution
Unusual, continuous running noise	Noise reeling/grinding	contact REHFUSS
Oil leaking	Sealing defective	contact REHFUSS
Output shaft not turning, although motor running or input shaft is turned	Connection shaft-hub in gear is interrupted	Return to REHFUSS for repair.
Changing noise and/or vibrations occurring	Coupling worn, short term transmission of torque by contact with metal Screw for fastening hub axial loose.	Replace coupling Tighten screw and protect
Premature wearing of coupling	Contact with aggressive oils, influence of Ozone, ambient temperature to high etc. which cause a physical change of coupling or too high temperatures, overload	contact REHFUSS

7.3 Malfunction on free input shaft

Problem	Possible cause	Solution
Unusual, continuous running noise	Noise reeling/grinding damaged on bearing	Contact REHFUSS
Oil leaking	Sealing defective	contact REHFUSS
Output shaft not turning, although input shaft is turned	Connection shaft-hub in gear is interrupted	Return to REHFUSS for repair

8 Mounting positions

8.1 General information about mounting positions

Description of mounting positions

The following figures show position of gearbox on the various mounting positions

8.2 Mounting position SR 1-step

- Breather plug
- ◐ Oil level
- Drain plug

B3		B8		V1		V6	
B6		B5 B14		V3		V18	
B7		B34		V5		V19	

Position of terminal box

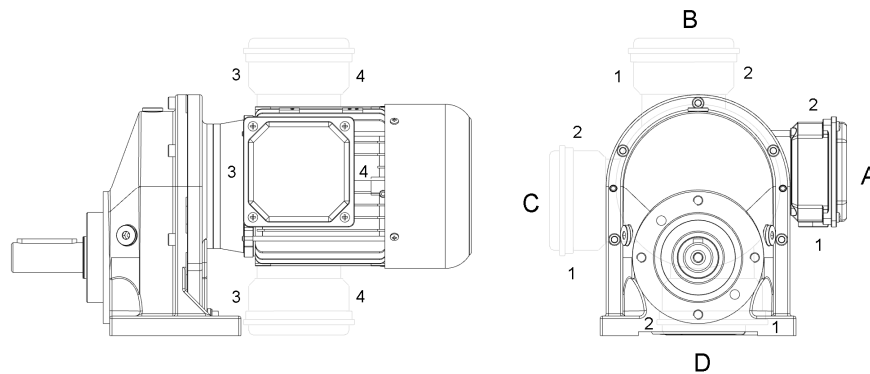

Normally and unless otherwise specified the Terminal box is in position A and the cable entry is in pos. 1. If other terminal box or cable entry positions are required they are to be specified when ordering.

With brake motors only cable entry positions 1 or 2 are possible..

8.3 Mounting position SR 2-step

- Breather plug
- ◐ Oil level
- Drain plug

B3		B8		V1		V6	
B6		B5 B14		V3		V18	
B7		B34		V5		V19	

Position of terminal box

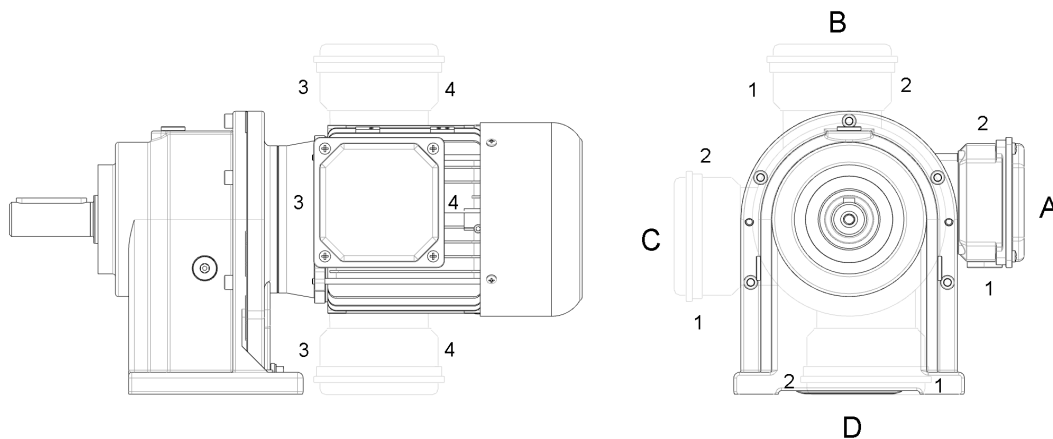

Normally and unless otherwise specified the Terminal box is in position A and the cable entry is in pos. 1. If other terminal box or cable entry positions are required they are to be specified when ordering.

With brake motors only cable entry positions 1 or 2 are possible..

8.4 Mounting position FG

- Breather plug
- ◐ Oil level
- Drain plug

B3		B6		V1	
B8		B7		V3	

Position of terminal box

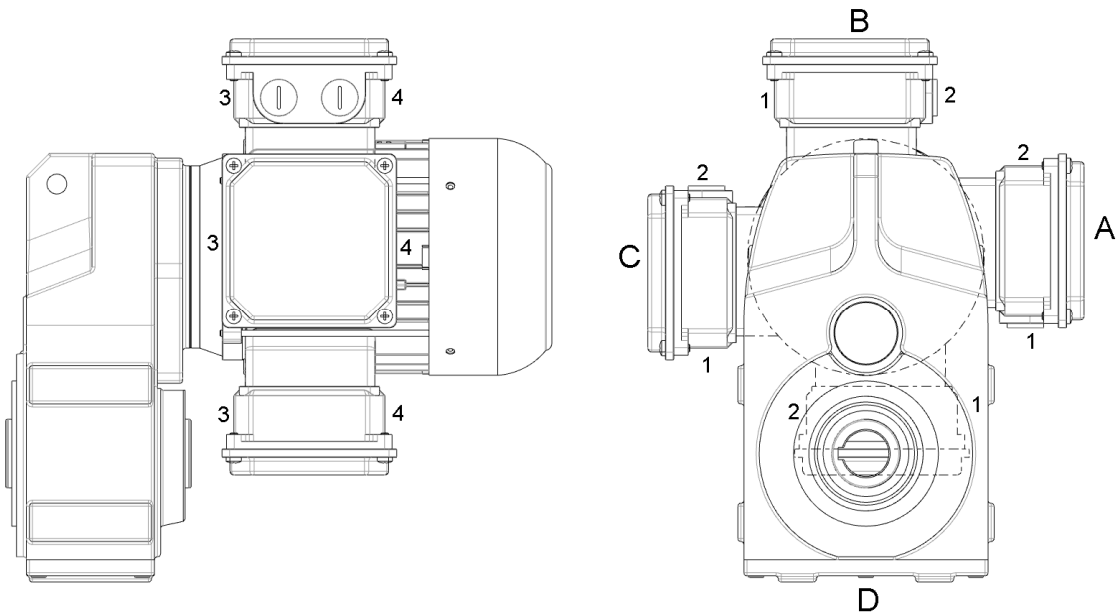

Normally and unless otherwise specified the Terminal box is in position A and the cable entry is in pos. 1. If other terminal box or cable entry positions are required they are to be specified when ordering.

With brake motors only cable entry positions 1 or 2 are possible..

8.5 Mounting position S

Schneckengetriebe

Worm gearbox

Réducteur à vis sans fin

Schneckengetriebemotoren

Worm geared motors

Motoréducteurs à vis sans fin

Einbaulagen

Mounting configurations

Positions de montage

- Entlüftung
- ◐ Ölstand
- Ablaß

- Breather plug
- ◐ Oil level
- Drain plug

- Désaération
- ◐ Niveau d'huile
- Vidange

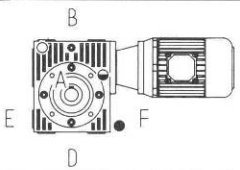
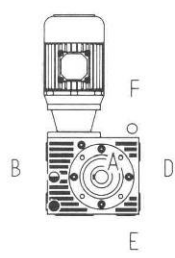
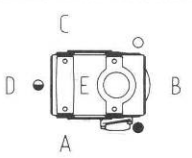
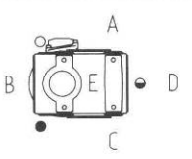
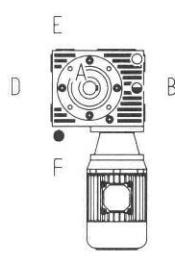
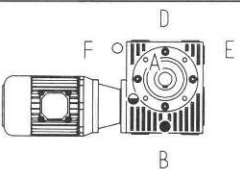
Bauform Mounting position Position de montage		Bauform Mounting position Position de montage	
B3		V5	
B6			V6
B7			
B8			

Lage des Klemmenkastens

Position of terminal box

Position de la boîte de bornes

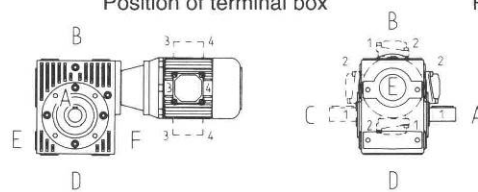

Im Normalfall und wenn bei der Bestellung nichts anders angegeben, sitzt der Klemmenkasten bei A, die Kabeleinführung bei 1. Wird eine davon abweichende Anordnung des Klemmenkastens bzw. der Kabeleinführung gewünscht, so ist dies bei der Bestellung anzugeben.

Normally and unless otherwise specified, the terminal box is in pos. A, and the cable entry is in pos. 1. If other terminal box or cable entry positions are required, they are to be specified when ordering.

Normalement, et si rien d'autre n'a été indiqué lors de la commande, la boîte de bornes se trouve en position A, l'entrée de câbles en position 1. Si le client désire une autre disposition de la boîte de bornes ou de l'entrée de câbles, prière de l'indiquer lors de la commande.

Bei Bremsmotoren ist die Kabeleinführung nur bei 1 oder 2 möglich

With brake motors only cable entry positions 1 or 2 are possible.

Pour les moteurs-freins, l'entrée de câbles ne peut être qu'en position 1 ou 2.

8.6 Mounting position SS

Stirnrad-
Schneckengetriebe
Stirnrad-
Schneckengetriebemotoren

Helical worm gearbox
Helical worm geared
motors

Réducteurs à
engrenages et vis sans fin
Motoréducteurs à
engrenages et vis sans fin

Einbaulagen

Mounting configurations

Positions de montage

- Entlüftung
- ◐ Ölstand
- Ablass

- Breather plug
- ◐ Oil level
- Drain plug

- Désaérag
- ◐ Niveau d'huile
- Vidange

Bauform Mounting position Position de montage		Bauform Mounting position Position de montage	
B3		V5	
B6			
B7		V6	
B8			

Lage des Klemmenkastens

Position of terminal box

Position de la boîte de bornes

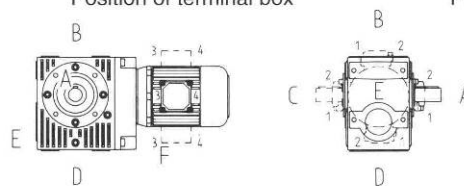

Im Normalfall und wenn bei der Bestellung nichts anders angegeben, sitzt der Klemmenkasten bei A, die Kabeleinführung bei 1. Wird eine davon abweichende Anordnung des Klemmenkastens bzw. der Kabeleinführung gewünscht, so ist dies bei der Bestellung anzugeben.

Normally and unless otherwise specified, the terminal box is in pos. A, and the cable entry is in pos. 1. If other terminal box or cable entry positions are required, they are to be specified when ordering.

Normalement et si rien d'autre n'a été indiqué lors de la commande, la boîte de bornes se trouve en position A, l'entrée de câbles en position 1. Si le client désire une autre disposition de la boîte de bornes ou de l'entrée de câbles, prière de l'indiquer lors de la commande.

Bei Bremsmotoren ist die Kabeleinführung nur bei 1 oder 2 möglich

With brake motors only cable entry positions 1 or 2 are possible.

Pour les moteurs-freins, l'entrée de câbles ne peut être qu'en position 1 ou 2.

8.7 Mounting position SM(N) / SSM

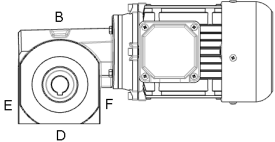
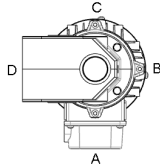
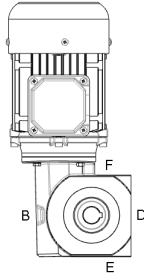
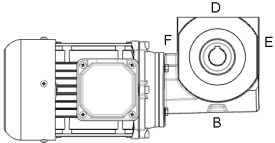
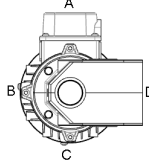
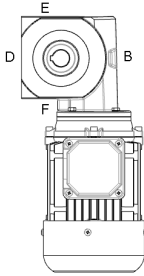
B3		B6		V5	
B8		B7		V6	

Position of terminal box

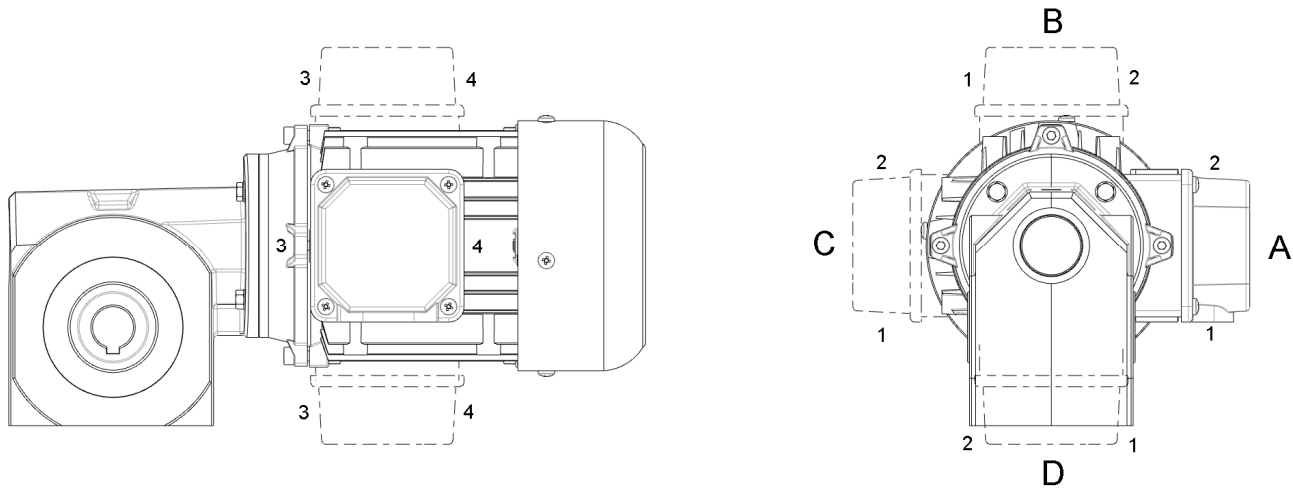

Normally and unless otherwise specified the Terminal box is in position A and the cable entry is in pos. 1. If other terminal box or cable entry positions are required they are to be specified when ordering.

With brake motors only cable entry positions 1 or 2 are possible..

Notes to SM(N) / SSM Series



SM(N) / SSM – gears and geared motors are independent from mounting positions. For better orientation we show mounting positions for this series as well.

Please note: no breather valves nor oillevel screws nor drain screws can be fixed on SM(N) / SSM – gears and geared motors.

9 Lubricants

General

If not agreed specially REHFUSS supplies explosion proof drives with lubricant according to specification of gear and mounting position. For this it is essential to advise mounting position when ordering the drive. When design is amended later please contact REHFUSS necessarily.

Lubricant / Quantity

Please see the following table “capacity” for requested lubricant quantities. It is essential to watch oillevel screw for indicator of exact quantity. For allowed lubrications please see table “lubrications”.

Grease for rolling bearings

Rolling bearings of explosion proof gears and motors are supplied filled with below stated greases. Rehfuss recommends to replace grease as well when replacing lubricant.



Below quantities are needed :







For fast running bearings (Motor and gearbox –input side) fill hollow spaces between rolling elements up to 1/3

For slowly running bearings (in gearbox and gearbox output side): Fill 2/3 of hollow spaces with grease

Table: Capacity in cm³

Getriebe Gearbox Réducteur	Bauform			Mounting position			Position de montage			
	B3	B6/B7	B8	V5	V6	B5	B5 B6/B7	B5 B8	V1	V3
Stirnradgetriebe 1-stufig Helical gearbox 1-stage Réducteur à engrenages 1-étage										
SR 120	150	250	400	275	400	200	250	400	275	350
SR 130	300	450	650	600	600	300	450	650	600	600
SR 140	400	700	1100	1000	1000	400	700	1100	1000	1000
SR 160	1000	1200	1600	1800	1600	750	1100	1500	1400	1500
Stirnradgetriebe 2-stufig Helical gearbox 2-stage Réducteur à engrenages 2-étages										
SR 210	200	200	200	250	250	150	200	200	200	200
SR 220	250	250	300	300	400	200	250	300	325	400
SR 230	500	500	600	700	750	400	550	550	550	650
SR 240	700	700	800	950	1150	600	600	700	900	1000
SR 260	1300	1300	1300	2200	2100	1300	1150	1300	1900	1800
SR 270	4500	7500	6500	13000	11500	4000	7000	6500	13000	11000
Stirnradgetriebe 3-stufig Helical gearbox 3-stage Réducteur à engrenages 3-étages										
SR 320	400	400	450	700	600	300	350	450	600	600
SR 330	700	800	800	1300	1100	550	650	650	1150	950
SR 340	950	800	1000	1700	1750	850	650	800	1400	1500
SR 360	1500	2250	1800	3100	2850	1500	2100	1900	2800	2600
SR 370	4200	7200	6200	12700	11000	4000	7500	6200	12500	13000
Schneckengetriebe Worm gearbox Réducteur à vis sans fin										
SM 011	50	Synthetisches Öl Synthetic oil Huile synthét								
SM(N) 021	70									
SM(N) 031	120									
SM 041	200									
SM(N) 051	300									
SM 061	600									
Schneckengetriebe Worm gearbox Réducteur à vis sans fin										
S 030	250	300	300	300	300					
S 040	700	600	600	650	650					
S 050	1200	1100	1000	1300	1300					
Stirnrad-Schneckengetriebe Helical worm gearbox Réducteur à engrenages et vis sans fin										
SS 130	350	450	500	550	500					
SS 140	700	850	1200	1400	1200					
SS 150	1200	1350	1600	2400	1800					
SS 160	1700	2800	3600	3800	3600					
SS 170	3000	5000	6500	9000	6700					
Stirnrad-Schneckengetriebe Helical worm gearbox Réducteur à engrenages et vis sans fin										
SSM 121	190	Synthetisches Öl Synthetic oil Huile synthét								
SSM 131	220									
SSM 151	600									
SSM 161	1200									
Reibradgetriebe 1-stufig Variable speed friction drive 1-stage Variateur à friction 1-étage										
D 110	100	150	150	200	200	100	150	150	200	200
D 120	250	250	250	350	450	250	250	250	350	450
D 130	300	450	450	450	650	300	450	450	450	650
D23-RU23-1	400	520	400	800	875	400	520	400	800	875
D3-RU3	1400	Fließfett			Fluid grease			Graisse fluide		
Reibradgetriebe 2-stufig Variable speed friction drive 2-stage Variateur à friction 2-étages										
D 210	200	300/250	275	325	450	200	300/250	275	325	450
D 220	400	500/550	500	550	600	400	500/550	500	550	600
D 230	500	850/1000	1000	1000	1450	500	850/1000	1000	1000	1450
D23-RU23-2	850	900/700	550	800	1300	850	900/700	550	800	1300
Flachgetriebe Shaft mounted gearbox Réducteur à arbres parallèles										
FG 210	600	600	700						750	750
FG 220	800	800	800						1000	1000
FG 240	1900	1500	1400						1400	1200
FG 250	3000	3000	3200						3200	3200
FG 260	4000	4000	4200						4200	4200

Table: Lubrications

Anwendung (Typen) Application Utilisation	Schmierstoff Lubrication Lubrifiant	Umgeb.temp Amb.Temp. Temp.Amb. °C	ISO VG (cST) 40°C mm²/s	Rehfuß Standard	Agip	Mobil	Shell	ARAL	BP	Klüber	Castrol
SR  S  SS  FG 	Mineralöl Mineral Oil Huile mineral	-15 bis +40	VG150		BLASIA 150	Mobilgear XMP 150		Degol BG150 Plus	Energol GR-XF 150	GEM 1-150N	Alpha SP150
		-10 bis +40	VG220		BLASIA 220	Mobilgear XMP 220	Omala F220	Degol BG220 Plus	Energol GR-XF 220	GEM 1-220N	Alpha SP220
		-5 bis +40	VG320	Agip BLASIA 320	BLASIA 320	Mobilgear XMP 320	Omala F320	Degol BG320 Plus	Energol GR-XF 320	GEM 1-320N	Alpha SP320
		0 bis +50	VG680		BLASIA 680	Mobilgear XMP 680	Omala F680	Degol BG680 Plus	Energol GR-XF 680	GEM 1-680N	Alpha SP680
	Fett Grease Graisse	-20 bis +50		Castrol Spherol EPL2	GR-MU 2/3	Mobilux EP2	Alvania EP2	ARALUP HLP2	Energrease LS2 Energrease LS2-EP2	Klüberplex BEM 41.132	Castrol Spherol EPL2
SM(N)  SSM 	Synth. Öl (Polyglykol) Synthetic Oil (Polyglycol) Huile synthétique	-30 bis +10	VG150		BLASIA S150	Glygoyle 150	Omala S4 WE150	Degol GS150	Energyn SG-XP 150	Klübersynth GH 6-150	Alphasyn GS150
		-25 bis +25	VG220		BLASIA S220	Glygoyle 220	Omala S4 WE220	Degol GS220	Energyn SG-XP 220	Klübersynth GH 6-220	Alphasyn GS220
		-20 bis +40	VG320	Agip BLASIA S320	BLASIA S320	Glygoyle 320	Omala S4 WE320	Degol GS320	Energyn SG-XP 320	Klübersynth GH 6-320	Alphasyn GS320
		-10 bis +50	VG460		BLASIA S460	Glygoyle 460	Omala S4 WE460	Degol GS460	Energyn SG-XP 460	Klübersynth GH 6-460	Alphasyn GS460
		-5 bis +60	VG680			Glygoyle 680	Omala S4 WE680	Degol GS680	Energyn SG-XP 680	Klübersynth GH 6-680	Alphasyn GS680
	synth.Fett Synth.Grease Graisse synth.	-20 bis +40		Mobil Chassis LBZ		Mobil Chassis LBZ	Alvania RLB 2		Energrease SY 2202	Isoflex Topas NCA 52 Petamo	Speerol SY 2202
	Lebensmittel verträgl.Öl. (synthetisch) lubricant for food industrie (synthetic) Huile approuvè pour qualité alimentaire (synth)	-20 bis +40	VG320	VÖLKEL HELVOSYT SLMG 320		SHC Cibus 320	Cassida WG320			Klübersynth UH1 6-320	Tribol Food-Proof 1800/320
	Lebensmittel verträgl.Fett (synthetisch) grease for food industry (syntetic) Graisse approuvè pour qualité alimentaire (synth)	-20 bis +40		BOSS Bossplex 5702 EP		Mobilgrease FM222	Cassida RLS2			Klübersynth UH1 14-151	Obeen UF2
Wälzlager Bearings Roulements	Fett Grease Graisse	-30 bis +60				Mobilux EP2	Alvania EP3	ARALUP HL3	BP Energrease LS3	Klüberplex BEM 41.141	
	Synth.Fett Synth.Grease Graisse synth.	+60 bis +100								Klübersynth HB 74-401	

Contents

issued 03/2022

1	Important Notes	54
2	Safety Notes	55
2.1	Safety Notes Motors	55
2.2	Transport/Storage	55
2.3	Installation/Assembly	55
2.4	Inspection/Maintenance	55
3	Assembly	56
3.1	Basic Assembly Three-phase-motor	56
3.2	Basic Assembly direct current discbrake	57
3.3	Function direct current discbrake	57
4	Mechanic Installation	58
4.1	Before you start	58
4.2	Preparations	58
4.3	Installation of motor	59
5	Electric Installation	60
5.1	Wiring notice	60
5.2	Operation with frequency inverter	60
5.3	Switch operation	60
6	Motors and Brakemotors	61
6.1	General Notes	61
6.2	Protection	61
6.3	Cable connections	61
6.4	Protection against inadmissibly high temperatures	61
6.5	Protection with motor protection switch only	61
6.6	Protection with temperature sensors	61
6.7	Connecting motor	61
6.7.1	Check cross section	62
6.7.2	Check winding connections	62
6.7.3	Temperature sensor	62
6.8	Connect brake	62
6.8.1	Note limiting value of switch energy	63
6.8.2	Check function of brake	63
6.8.3	Check cross sections	63
6.8.4	Ambient temperature	63
7	Commissioning	63
7.1	Conditions for commissioning	63
8	Malfunctions	64
8.1	Malfunctions motor	64
8.2	Malfunctions brake	64
8.3	Malfunctions	65

Contents

9	Inspection	66
9.1	Inspection / Maintenance Motor	66
9.2	General Notes	67
9.3	Bearings	67
9.3.1	Bearings with life-time lubrication	67
10	Operating conditions Brake	67
10.1	Installation	68
10.2	Adjustment and checking data	68
10.3	Adjustment of braking torque	68
10.4	Adjustment and regulation of air gap	69
10.5	Subsequent installation of hand lifting	69
10.6	Classification of brake to size of motor	70
10.7	Technical data of brake	70
11	Spare parts	71
11.1	General Notes	71

1 Important Notes

Always follow the safety and warning instructions in this manual!

**Electrical hazard**

Possible consequences: Severe or fatal injuries.

**Hazard**

Possible consequences: Severe or fatal injuries.

**Hazardous situation**

Possible consequences: Slight or minor injuries.

**Harmful situation**

Possible consequences: Damage to the drive and the environment

**Tips and useful information**

A requirement of fault-free operation and fulfilment of any rights to claim under guarantee is that you adhere to the information in the operating instructions. Consequently, read the operating instructions before you start operating the drive!

Keep the operating instructions in the vicinity of the unit since they contain important information about servicing the unit.

Waste disposal

This product exists of:

- Iron
- Aluminium
- Copper
- Plastics
- Electronic components

Please dispose of the parts in accordance with the applicable regulations

2 Safety Notes

2.1 The following safety notes apply to the usage of motors

When using geared motors please refer also to the safety notes for gearboxes in the corresponding operating manual

Also please note the additional safety notes in the individual chapters of this operating manual.

All transport, storage, fitting, connection, installation, as well as repair and maintenance works may only be performed by qualified personnel. The following points must be given particular consideration:

- corresponding detailed operating manual(s) and wiring diagrams
- warning labels on motor/geared motor
- system-specific regulations and requirements
- relevant national/regional regulations for safety and accident prevention

Severe damages to persons and property can be caused by:

- inappropriate usage
- faulty installation or handling
- impermissible removal of necessary protective covering or housing.

Designated use

These motors are intended for industrial use; they correspond to the relevant standards and regulations and meet the requirements of the low voltage directive 73/23/EWG.

The technical data and information about the relevant regulations are to be found on the nameplate and in the documentation. All instructions must be strictly observed at all times!

2.2 Transport/Storage

Please check all shipments immediately upon receipt for possible damages in transport. Announce these without delay to the forwarding agent. Start up has to be eliminated if necessary.

Fix screwed transport rings. They are only designed for the weight of the gearbox / geared motor, no additional load can be added.

If necessary use adequate sufficient means of transport. Please remove existing transport securities before start-up.

2.3 Installation/Assembly

Please follow instructions in chapter „Mechanical Installation“!

2.4 Inspection/Maintenance

Please follow instructions in chapter „Inspection/Maintenance“!

3 Assembling



Below drawing has to be understood in principle. It is only to be used as a reference to the spare parts lists. Variations depending on size of motor and type are possible!

3.1 Basic assembly Three-phase motor

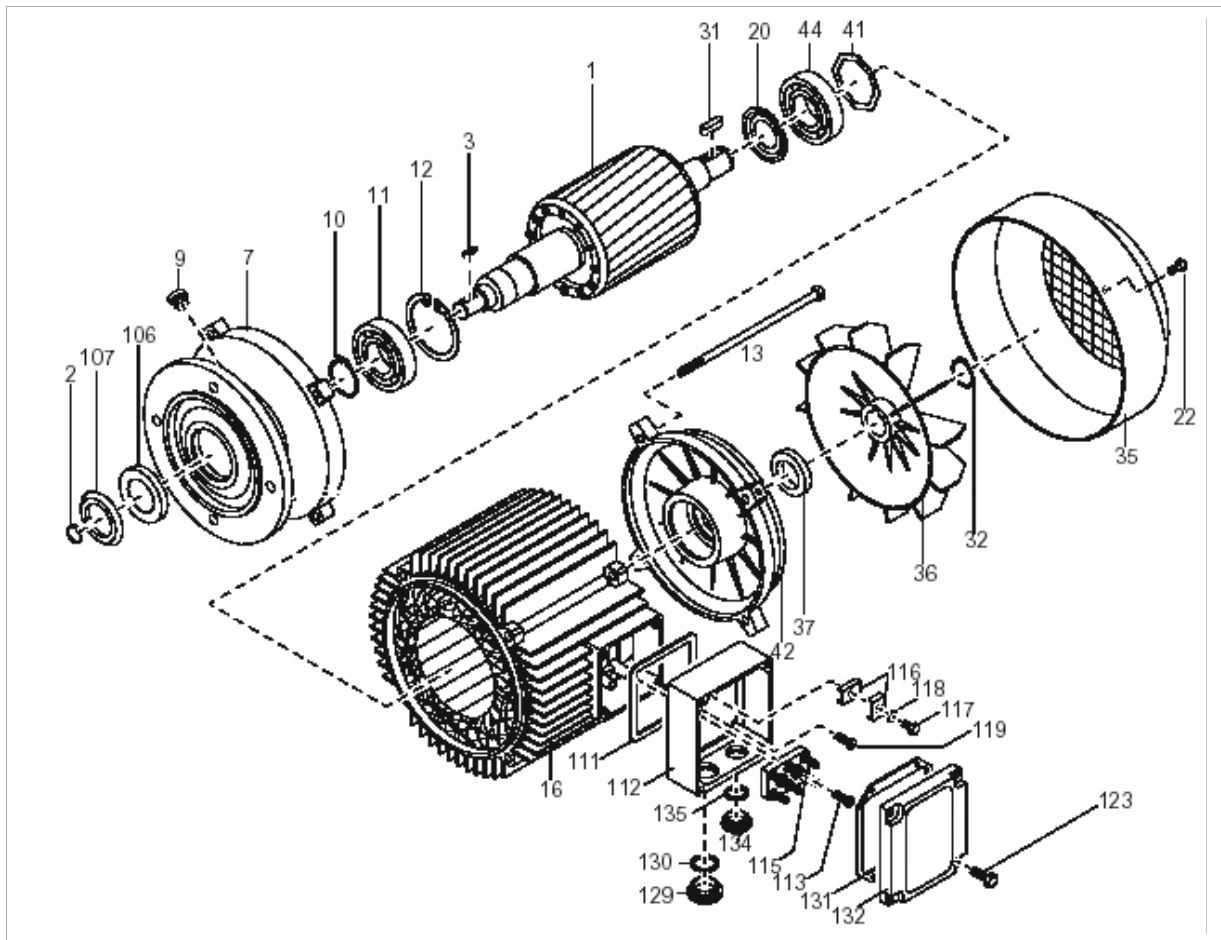

- | | | |
|-------------------------|---------------------------------|----------------------|
| 1 Rotor, cpl. | 41 Equalizing ring | 131 sealing |
| 2 Circlip | 42 Non drive-end bearing shield | 132 Terminal box lid |
| 3 Key | 44 Grooved ball bearing | 134 Screw plug |
| 7 Flanged end shield | 106 Shaft sealing | 135 Sealing |
| 9 Screw plug | 107 Oil-flinger ring | |
| 10 Circlip | 111 gasket | |
| 11 Grooved ball bearing | 112 Terminal box lower part | |
| 12 circlip | 113 Machine screw | |
| 16 Stator, cpl. | 115 Terminal board | |
| 20 Nilosring | 116 Terminal yoke | |
| 22 Hex head bolt | 117 Hex head bolt | |
| 31 key | 118 Lock washer | |
| 32 Circlip | 119 Machine screw | |
| 35 cowl | 123 Hex head bolt | |
| 36 fan | 129 Screw plug | |
| 37 V-Ring | 130 Sealing | |

3.2 Basic assembly DC disc brake

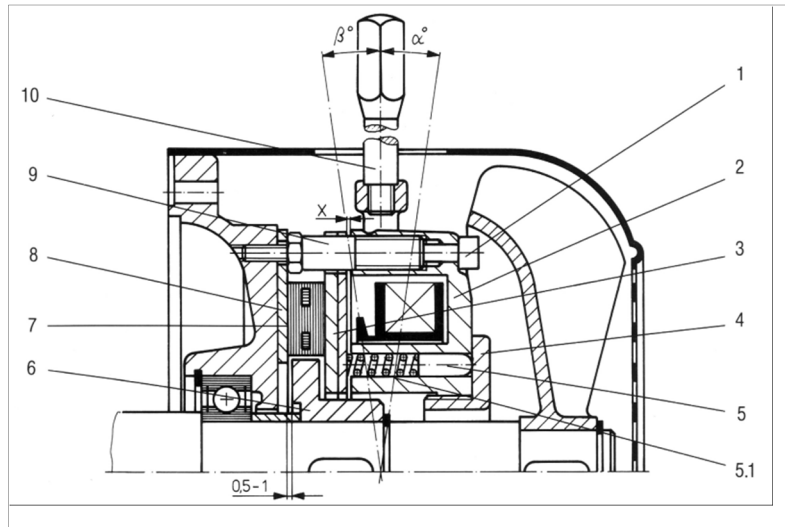

3.3 Function of DC disc brake

At zero current the springs (5.1) press the armature plate (3) and the friction plate (7) against the attachment surface. The friction plate (7) is torsionally secure; yet connected axially movable with the hub (6), The hub is firmly mounted on the shaft, thereby locking it.

After applying the voltage, the DC coil produces a magnetic field in the magnet (2) which attracts the armature plate (3) against the spring force thereby the brake lining (7) is released and allows the shaft to rotate.

The brake is fixed with the fixing screws (1). The air gap is adjusted with screws (1) loosened and with zero current by means of a feeler gauge to the nominal size "X" according to table. After a uniform adjustment the screws are tightened and the brake is ready to operate.

The abrasion caused by dynamic braking results in an enlargement of the air gap. The function of the brake can only be granted by regular control and readjustment when air gap "X" is reached. The minimum permissible friction thickness „g“ must at no times be under-run. The distance of 0.5 ... 1 mm to the attachment surface indicated in the drawing was chosen with respect to a possible shaft play. Through this measurement a dragging of the hub against the mounting surface can be avoided.

A hand release can be mounted to the brake subsequently. Important here is the assembly dimension "m". A wrong adjustment can cause the loss of the braking effect, especially when the brake torque is reduced or the magnet is energized by over voltage.

Ex factory the brake is set at the nominal value. Turning the adjustment nut (4) decreases the brake torque as shown in drawing, at the same time switching times will change accordingly.

When brakes BR07 through BR10 are mounted vertically lifetime of brakes at high speeds

($n > 1500$ 1/min) can be prolonged by using a special lining system. Please contact our sales specialists.

Friction faces have to be free of grease and oil!

4 Mechanic Installation



Please follow the safety instructions in **chapter 2** when installing

4.1 Before you start

The drive may only be fitted when

the information on the nameplate of the drive corresponds with the mains voltage respectively the output voltage of the frequency inverter.

The drive is not damaged (no damage by transport or storage)

The following requirements are achieved:

- Ambient temperature between -25 °C and $+40\text{ °C}$
- No oil, acids, gas, vapours, radiation etc.
- Altitude of site max. 1000 m above NN
- Note restrictions for encoders
- Special version: drive according to environmental conditions

4.2 Preparations

Ends of motor shafts must be completely free of anti-corrosion agents, contamination or other impurities. Do not let solvent get in contact with bearings or seals – danger of damage of the material!

Storage Motors



Please consider shorter working life of ball-bearing grease after extended storage periods more than 1 year.

- Check if motor gathered moisture by extended storage. Check insulation resistance for this purpose (measuring voltage 500 V).

Insulation resistance depends highly on temperature. If insulation resistance is not sufficient motor has to be dried

Drying of Motor

Warm up Motor

- with hot air or
- by isolation transformer

Stop drying when minimum insulation resistance is exceeded.

Check terminal box, if

- interior is dry and clean
- fitting and fixing parts are free of corrosion
- joint seals are correct
- cable connections are tight, otherwise clean or replace

4.3 Installation of Motor



The motor respectively geared motor must only be installed in stated version on a flat, shock free and torsion tight surface.

Align motor and working machine thoroughly, so that output shafts will not be loaded inadmissibly. (Please note allowed lateral and axial forces).

Make sure no shock or eccentricity on shaft ends.

Protect vertically mounted types from penetration of fluid or alien bodies by covering (protection cover).

Cooling air inflow has to be unobstructed, and outgoing cooling air of other units must not be taken in again.

Balance parts which are drawn on shaft later with half key (motor shafts are balanced with half key).

Existing condensation drain holes are sealed and may only be opened when necessary. The condensation drain holes must generally be kept sealed in order to maintain the specified IP protection class.

When using pulleys only belts that do not load electrostatically may be used.

When using brake motors with manual airing screw in either hand lever (for reversing hand airing) or tapped bolt (for fixed hand airing)

Installation in damp locations

Terminal box should possibly be fixed so that cable entries are positioned downwards

Coat threads of cable connections and glands with sealant and fasten tightly – then coat again

Seal cable entries well

Clean sealing faces of terminal box and terminal box cover well before reassembly. Seals have to be glued one-sided. Replace embrittled seals.

If necessary replace corrosion protective coating.

Check enclosure

Tolerances on assembling

Shaft end

Diameter tolerance according to DIN 748

- ISO k6 at $\varnothing \leq 50$ mm
- ISO m6 at $\varnothing > 50$ mm
- centre bore according to DIN 332, Form DR..

Flanges

entering edge tolerance according to DIN 42948

- ISO j6 at $\varnothing \leq 230$ mm
- ISO h6 at $\varnothing > 230$ mm

5 Electrical Installation



It is essential to comply with the safety notes in chapter 2 during installation

Consider additional notes

In addition to general instructions for electric installation of low-voltage equipment (for example DIN VDE 0100, DIN VDE 0105 in Germany) it has to be considered

Use wiring diagrams



Connect motors only according to the wiring diagram which is attached to the motor.

Do not connect or start up the motor if this wiring diagram is missing!

5.1 Wiring notes

Protecting brake control systems against interference

Do not route brake cables alongside switch-mode power cables, as otherwise there is a risk of disrupting brake control systems.

Switched-mode power cables include in particular:

Output cables from frequency and servo controllers, converters, soft start units and brake units

Feeder cables for brake resistors and similar options

Protecting motor protection devices against interference

Route separately shielded feeder cables together with switched-mode power lines in one cable

Do not route unshielded feeder cables together with switched-mode power lines in one cable

5.2 Special aspects for operation with a frequency inverter

When motors are powered from inverters you must adhere to the wiring instructions issued by the inverter manufacturer. It is essential to observe the operating instructions for the frequency inverter.

5.3 Special aspects in switching operation

When the motors are used in switching operation, possible interference of the switch-gear must be excluded by ensuring suitable wiring. According to EN 60204 (electrical equipment of machines) motor wirings must have interference suppression to protect the numerical or programmable logic controllers. As it is primarily switching operations that cause interference, we recommend installing protective circuitry in the switching devices.

6 Motors and brake motors

6.1 General notes

These motors are for industrial use. They correspond to valid rules and requirements. The technical data and specification of permissible conditions are to be found on nameplates and in the documentation. All instructions have to be observed strictly!

6.2 Protection class

The motors are supplied ex factory with at least enclosure class IP 54 according to EN 60034.

6.3 Cable connections

Use for cable entry only cable connections which ensure the protection class stated on name plate.

6.4 Protection against unacceptable high surface temperatures

The motors ensure a safe operation under the operation conditions stated on the name plate. The motors must be provided with overload safety device to prevent unacceptable high temperatures.

Stop can be made with motor protection switch or thermistor temperature sensor.

6.5 Protection with motor protection switch only

When installation is made with motor protection switch according to EN60947 please note:

- The motor protection switch must stop immediately in the event of phase failure
- The motor protection switch must be set to the nominal motor current according to name plate
- For pole-changing motors each pole has to be provided with motor protection switches protected against each other

6.6 Protection with thermistor temperature sensor

Please follow the operating instructions for installing thermistor temperature sensors

6.7 Connect motor



Please follow strictly the valid wiring diagram. Do not connect or start up the motor if this wiring diagram is missing!

6.7.1 Check cross sections

Check cross sections of lines as to nominal current of motor, effective installation rules and requirements in site.

6.7.2 Check winding connections

Check winding connections in terminal box and fasten if necessary

6.7.3 Temperature sensors

Connect temperature sensors according to manufacturer's instructions and attached terminal diagram with lines separated from mains cable.

6.8 Connect brake

The magnet coil has to be connected to the DC voltage. For connection to the AC mains various rectifiers are available. Connection of these rectifiers is shown on below pictures.

For AC side switching the switching contact of the rectifier is bridged.

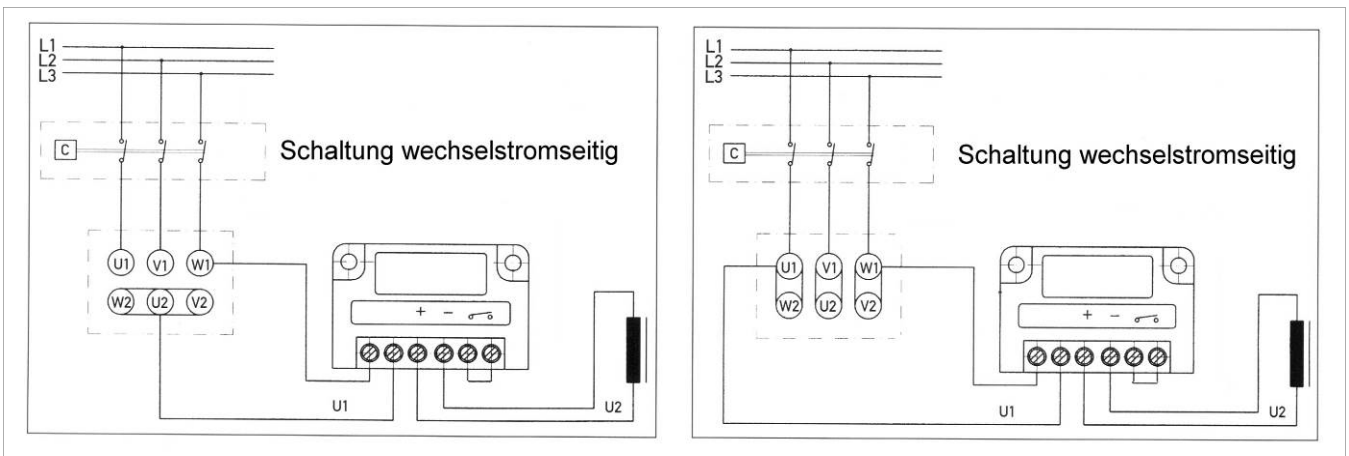

For DC-side switching the switch contact is switched.

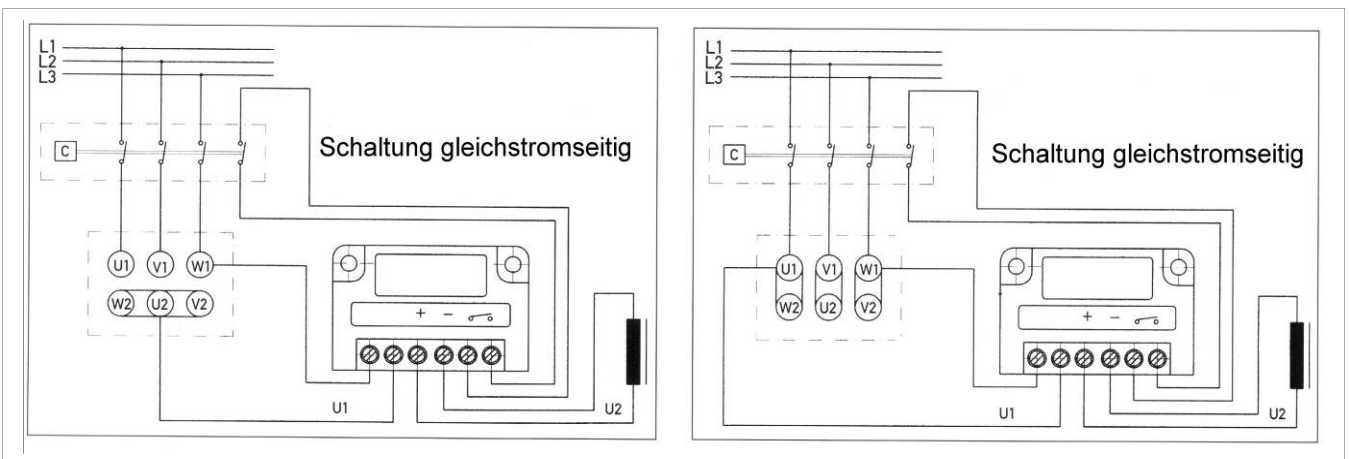

6.8.1 Consider limits of permissible switching operations

The limits of the permissible switching operation have to be considered strictly.

6.8.2 Check function of brake

Before starting check that the brake is in proper working order, so that grinding of brake lining and therefore impermissible heating is avoided. Motor must not start against closed brake. Configure the wiring so that brake is aired before the motor is switched on.

vermeiden. Der Motor darf nicht gegen die geschlossene Bremse anlaufen.

Schaltung so ausführen, dass zuerst die Bremse gelüftet und dann erst der Motor eingeschaltet wird.

6.8.3 Check cross sections

Cross sections of connection lines must be measured appropriate to grant proper function of brake.

6.8.4 Ambient temperature

The performance stated refers to the operating mode stated on the name plate and a max. ambient temperature of 40°C and an altitude of site up to 1000 m above sea level.

7 Starting

7.1 Requirements for starting



Please follow strictly the safety instructions in **chapter 2**

Make sure before starting that

- The drive is not damaged and not blocked
- After extended storage the instructions according to „preparations“ are to be followed
- All connections are made correctly
- The rotating direction of the motor/geared motor is correct
- All protection covers are installed correctly
- All motor protection devices is active and adjusted to the rated current of the motor
- The returning hand airing is used for lift drives
- No other source of danger is existing

Make sure while starting that

- The motor is running properly (no overload, no fluctuation of speed, noise etc.)

The corresponding brake torque is adjusted for the respective application

8 Malfunctions

8.1 Malfunction of motor

Problem	Possible cause	Remedy
Motor does not start	Connection interrupted	Check connections, correct if necessary
	Brake not aired	See chapter „malfunction of brake“
	Safety fuse blown	Replace safety fuse
	Motor protection is activated	Check motor protection for correct setting, correct error if necessary.
	Motor protection does not switch, mistake in control	Check motor protection control, correct error if necessary
Motor does not start or only with difficulty	Motor is designed for delta connection but is used in star connection	Correct circuit
	Voltage or frequency diverge much at least during switch-on	Provide better power supply, check cross sections of connecting harness
Motor does not start in star connection, only in delta connection	Torque not sufficient in star connection	Switch on directly if delta inrush is not too great: otherwise use a larger motor or a special version (contact us)
	Contact fault on delta star switch	Rectify fault
Incorrect direction of rotation	Motor connected incorrectly	Swap over two phases
Motor hums and has high current consumption	Brake does not release	See chapter „Brake problems“
	Winding defective	Send motor to a specialist workshop for repair
	Rotor rubbing	
Fuses blow or motor protection trips immediately	Short circuit in line	Correct circuit
	Short circuit in motor	Send motor to specialist workshop for repair
	Lines connected incorrectly	Correct circuit
	Ground fault on motor	Send motor to specialist workshop
Severe speed loss under load	Overload	Perform power measurement, use larger motor or reduce load if necessary
	Voltage drops	increase cross section of connecting harness
Motor heats up excessively (measure temperature)	Overload	perform power measurement, use larger motor or reduce load if necessary
	Inadequate cooling	Correct cooling air supply or clear cooling air passages, retrofit forced cooling fan if necessary
	Ambient temperature too high	Adhere to permitted temperature range
	Use delta connection for motor rather than star connection as provided for	Correct circuit
	Loose contact in connecting harness (one phase missing) p	Rectify loose contact
	Fuse blown	Look for and rectify cause (see above), replace fuse
	Supply voltage deviates from rated motor voltage by more than 5%. A higher voltage has a particularly unfavourable effect in these, the no-load current is already close to the rated current even when the voltage is normal	Adapt motor to supply voltage
	Rated operation type (S1 to S10, DIN 57530) exceeded, e.g. through excessive starting frequency.	Adjust rated operation type of motor to required operating conditions; if necessary call in a specialist to determine correct line
Excessively loud	Ball bearing compressed, contaminated or damaged	Re-align motor, inspect ball bearing, grease if necessary replace
	Vibration of rotating parts	Rectify cause, possibly imperform power measurement, use larger motor or reduce load if necessary
	Foreign bodies in cooling air passages	Clean the cooling air passages

8.2 Brake problems

Problem	Possible cause	Remedy
Brake does not release	Incorrect voltage on brake control unit	Apply correct voltage
	Brake control unit failed	Install a new brake control system, check internal resistance and insulation of brake coil, check switchgear
	Max. permitted working air gap exceeded because brake lining worn down	Measure and set working air gap
	Voltage drop along connecting harness >10%	Provide for correct connection voltage; check cable cross
	Inadequate cooling, brake overheats	Replace brake rectifier
Motor does not brake	Brake coil has winding fault or short circuit to exposed conductive part	Replace complete brake and brake control system (specialist workshop), check switchgear
	Working air gap not correct	Measure and set working air gap
	Brake lining worn down	Replace entire brake disc
	Incorrect braking torque	Change the braking torque
Brake is applied with time lag	Hand release not set correctly	Set the setting nuts correctly
	Brake is switched on AC Voltage side	Switch on DC and AC voltage sides, please refer to wiring diagram
Noise in the brake area	Gearing wear caused by jolting startup	Check project planing
	Pulsating torques due to incorrectly set frequency inverter	Check/correct setting of frequency inverter according to operating instructions

8.3 Malfunctions during operation

The symptoms described in the „Motor Malfunctions“ section may also occur when the motor is operated with a frequency inverter. Please refer to the frequency inverter operating instructions for the significance of the problems which occur and to find information about rectifying the problems.

Please have the following information to hand if you require the assistance of our customer service:

- Data from the name plate (complete)
- Nature and extend of the problem
- Time and peripheral circumstances of the fault
- Presumed cause

9 Inspection



Use only genuine spare parts in accordance with the valid spare parts list!
 Always install a new brake control system at the same time as replacing to brake coil!
 Motors can become very hot during operation – danger of burns!
 Secure hoist drives or lower them (danger of falling).
 Isolate the motor and brake from the supply before starting work, safeguarding them against unintentional power-up!

Unit / unit part	Frequency	What to do?
Brake	If used as a working brake: At least every 3000 hours of operation	Inspect the brake Measure the brake thickness Brake disc, lining Measure and set working air gap Pressure plate Carrier/gearing
Motor	Every 10,000 hours of operation	Inspect the motor: Check ball bearings and change if necessary Change oil seal Clean the cooling air passages
Tachogenerator, Encoder		Inspektion / Wartung gemäß zugehöriger Betriebsanleitung

The periods of wear are affected by many factors and may be short. The machine designer must calculate the required inspection/maintenance intervals in accordance with the project planning documents.

9.1 Inspection / maintenance Motor



Isolate the motor and brake from the supply, safeguarding them against unintentional power-

Basic procedure:

1. Remove the forced cooling fan and encoder, if installed
2. remove flange or cowl and fan
3. Remove the screws from the drive-end bearing end shield and the non-drive-end bearing end shield, release stator from drive-end bearing end shield, lift non-drive-end bearing end shield with motor shaft carefully off the stator.

Motors with brake

4. open the terminal box lid, unfasten the brake cable from the rectifier
Release brake from non-drive end bearing end shield
Remove the complete brake with the releasing lever (on version with manual brake release)
5. Visual inspection: Are there traces of gear oil or condensation inside the stator?
 - if not, continue with 9
 - if there is condensation, continue with 7
 - if there is gear oil, have the motor repaired by a specialist workshop
6. If there is moisture inside the stator:
 - with gearmotors: remove the motor from the gear unit
 - with motors without gear unit: remove the drive end flange
 - Remove the rotor.
7. Clean the winding, dry it and check it electrically
8. Replace the ball bearings
9. Replace the shaft seal in the drive end bearing shield
10. Reseal the stator seat and grease V-ring or labyrinth seal
11. Install the motor, brake and accessories
12. Check the gear unit

9.2 General notes

Depending on degree of spoiling the motors must be cleaned routinely over their full surface e.g. using dry compressed air.

The first inspection must be executed normally after approx. 500 operating hours, after 1 year at the latest. Follow-up inspections should, depending on the conditions of use, be executed at appropriate intervals, such as re-greasing and grease change intervals, but at least once a year

During inspections it must be checked that:

- the technical data specified on the nameplate are kept,
- no leakages (oil, grease, water) exist
- the running noise of the bearings and the smoothness of the motor have not deteriorated,
- all fastening bolts for electrical und mechanical connections are safe,
- the alignment of the motor lies within the allowable tolerances during coupling operation.

9.3 Bearings

9.3.1 Bearings greased for life-time

The bearings of the motors with life-time lubrication are maintenance free under normal operation conditions for 10,000 to 20,000 operating hours, but for no longer than 3 years.

For motors which have bearings sealed by two caps (2Z bearings) and with speeds up to 3,600 rpm the bearings should be replaced after 20,000 operating hours, after 3 years at the latest.

For motors sealed by a single cap (Z bearing) or a single bearing end cap the grease must be replaced

- After 20,000 operating hours for speeds up to 1 800 rpm
- After 10,000 operating hours for speeds up to 3 600 rpm

After 3 years at the latest, grease and bearings if necessary have to be replaced.

10. Operating conditions brake

Before installing the spring-loaded brake observe the following:

1. Provide a suitable 2nd friction ring. Plane friction surfaces made from cast iron or steel. The surface roughness R should not exceed 25 µm. Avoid sharp-edged interruptions in the friction surface. If such a surface is not available a friction disc or flange can be used optionally (available as accessories)
2. The eccentricity of the mounting hole circle to the shaft end shall not exceed the following values: size 00 ... 02 0.2mm; size 03 ... 06 0.4mm; size 07..10 0.5mm.
3. The angular deviation of the mounting surface to the shaft shall not exceed the following values: size 00 ... 03 0.04mm; size 04 and 05 0.05mm; size 06 and 07 0.06mm; size 08 ... 10 0.08mm (in reference to the bolt diameter).
4. The friction surfaces must be free from grease and oil.
5. Humidity, aggressive fumes and similar means can cause the rusting in of the friction lining. In such cases rustproof friction discs are optionally available.
6. The movement of the armature shall not be obstructed by foreign bodies penetrating into the nominal air gap. If necessary the protective rings (optionally) are to be used or other protective measures are to be taken.

10.1 Installation

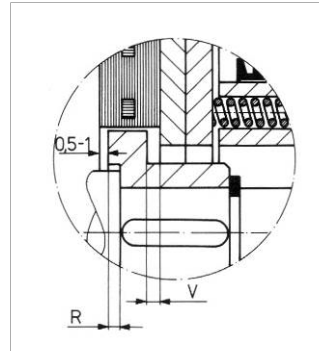

1. Mount the hub on the shaft and secure it axially. Absolutely avoid any damage to the hub and make sure that the hub cannot run against the 2nd friction surface. Considering the axial play of the shaft we recommend a distance of 0,5 ...1 mm.
2. Slide the friction ring on the hub. Be careful not to damage the friction lining through misaligned or tilted attachment (The lining must slide easy on the hub)
3. Attach the magnetic system (completely assembled) with head cap screws in doing so adjust the nominal air gap „X“ with a feeler gauge or by means of the adjustment spacers At that the brake must be in the power off mode. We recommend screws of the strength class 8.8 which should be tightened with the torque recommended by the manufacturers.

10.2 Setting and checking data

Size	Nominal air gap X [mm]	Max. permissible wear V [mm]	Readjsutment necessary at Xn [mm]	Min. permissible lining thickness g min [mm]	R [mm]	m [mm]
BR02	0,2	2,0	0,4	5,5	0,5	0,8
BR03	0,2	1,5	0,5	6,5	1,5	1,0
BR04	0,2	2,5	0,6	8,0	1,5	1,4
BR05	0,2	2,0	0,6	10,0	2,0	1,5
BR06	0,3	2,0	1,0	10,0	2,0	1,8
BR07	0,3	4,0	1,0	10,0	-	2,0
BR08	0,4	5,0	1,2	11,0	-	2,0
BR09	0,4	6,0	1,2	12,0	-	2,3
BR10	0,5	8,0	1,5	14,0	-	2,7

10.3 Adjustment of braking torque

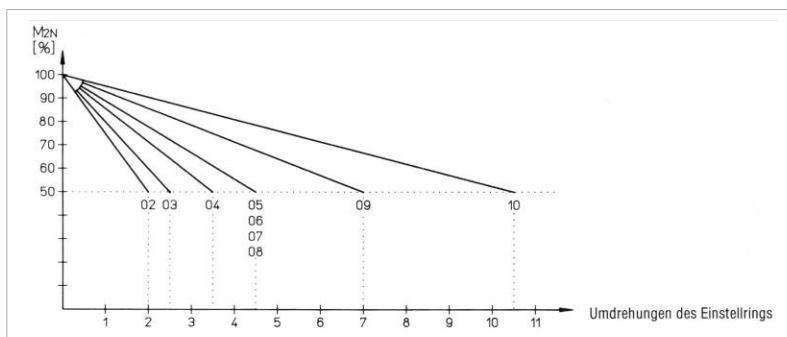

The braking torque is adjusted to the rated torque in the factory. It can be changed by turning the adjustment ring. Above figure shows the approximate torque change. By changing the adjustment ring a change of the switching times is caused!

10.4 Re-adjustment of clearance

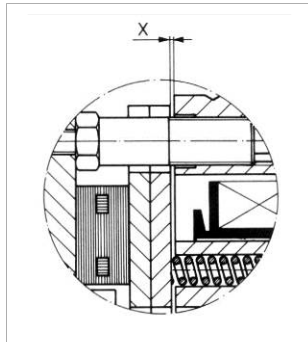

The normal air gap becomes larger due to wear. To guarantee a trouble-free function the air gap should be readjusted when the air gap „X“ is reached. To do that, disconnect the brake from load to avoid an uncontrolled motion of rotation

1. Loosen the head cap screws.
2. Adjust the air gap by turning the adjustment spacers. Please note that the adjustment is uniform at all points.
3. Tighten the head cap screws again.
4. Check the air gap again and repeat the procedure if necessary.
5. This procedure can be repeated as often as needed until the friction lining has reached the min. permissible thickness „g“. The friction lining and friction surfaces must be renewed and refinished.

10.5 Subsequent attachment of hand release

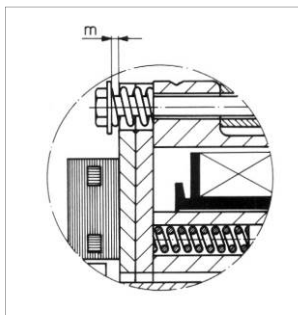

Push the screws with disks and springs through the provided bores into magnet and armature disk. Attach the hand release bracket and tighten it with self-locking nuts. The alignment dimension „m“ must be adjusted with attracted armature. The dimension „m“ applies to rated torque and operation with rated voltage. Please contact us in case of different operating conditions

10.6 Classification of brake to size of motor

Motor frame size	Motor extension	Type							
		BR02	BR03	BR04	BR05	BR06	BR07	BR08	BR09
		Brake torque [Nm]							
IEC	[mm]	5	10	20	40	60	100	150	250
56	43	X							
63	60	O	X						
71	60	O	X	X					
80	67	X	O	X					
90	75		X	O	X				
100	90		X	X	O	X			
112	95		X	X	X	O	X		
132 S	108				X	O	X	X	
132 M	108				X	X	O	X	
160	129					X	X	X	X
180	145					X	X	X	X

O=Standard size classification

10.7 Technical data brakes

Type		BR02	BR03	BR04	BR05	BR06	BR07	BR08	BR09
Brake torque	MBr (Nm)	5	10	20	40	60	100	150	250
Max. Speed	(1/min)	6000	6000	6000	6000	3600	3600	3600	1800
Coil rating	Ps (W)	22	28	34	45	55	85	76	105
Weat load	P _{rmax} (J/S)	80	100	130	160	200	250	300	350
Friction work per operation	Wrzul (J)	1500	3000	6000	12500	17500	25000	37500	52500
Friction until 0,1 mm wear is reached	WRx10 ⁶ (J)	16	30	42	70	85	140	170	230
Moment of inertia	J x10 ⁻³ (kgm ²)	0,015	0,045	0,173	0,45	0,86	1,22	2,85	6,65
Air gap	x (mm)	0,2	0,2	0,3	0,3	0,3	0,4	0,4	0,5
Max. permissible wear	(mm)	2,0	1,5	2,5	2,0	2,0	4,0	5,0	6,0
Readjustment at	(mm)	0,6	0,7	0,8	0,9	1,0	1,1	1,1	1,2

11 Spare parts

11.1 General notes

When ordering spare parts please always state the motor type and motor number (data to be found on the name plate) additional to the exact parts description.

With the exception of standardised commercially available and equivalent parts e.g. bearings only original parts must be used.

This applies in particular to seals and connecting terminals.

